



Agnel Charities'  
FR. C. RODRIGUES INSTITUTE OF TECHNOLOGY, VASHI  
Department of Mechanical Engineering



# Mechanical Engineering Students' Association

*Presents*

# URJA

2021-2022

# MACHINE

# MIND

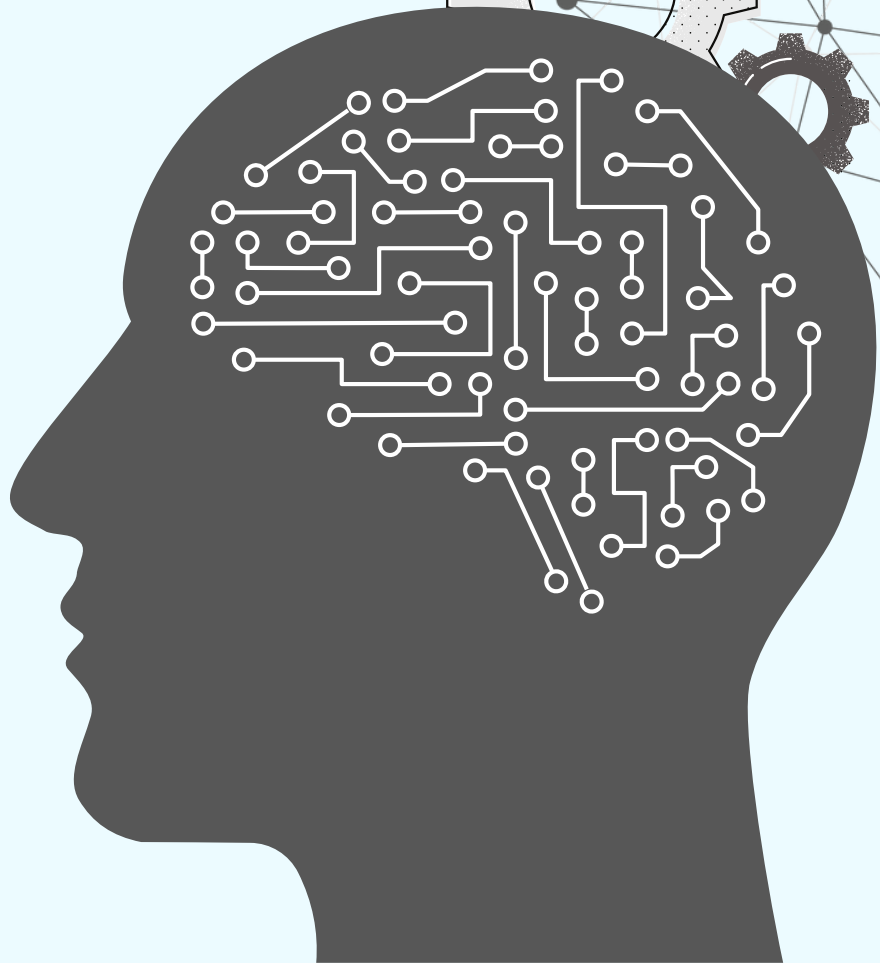

**Agnel Charities'**  
**Fr. C. Rodrigues Institute of Technology, Vashi**

**Department of Mechanical Engineering**  
**Mechanical Engineering Students' Association**

Presents

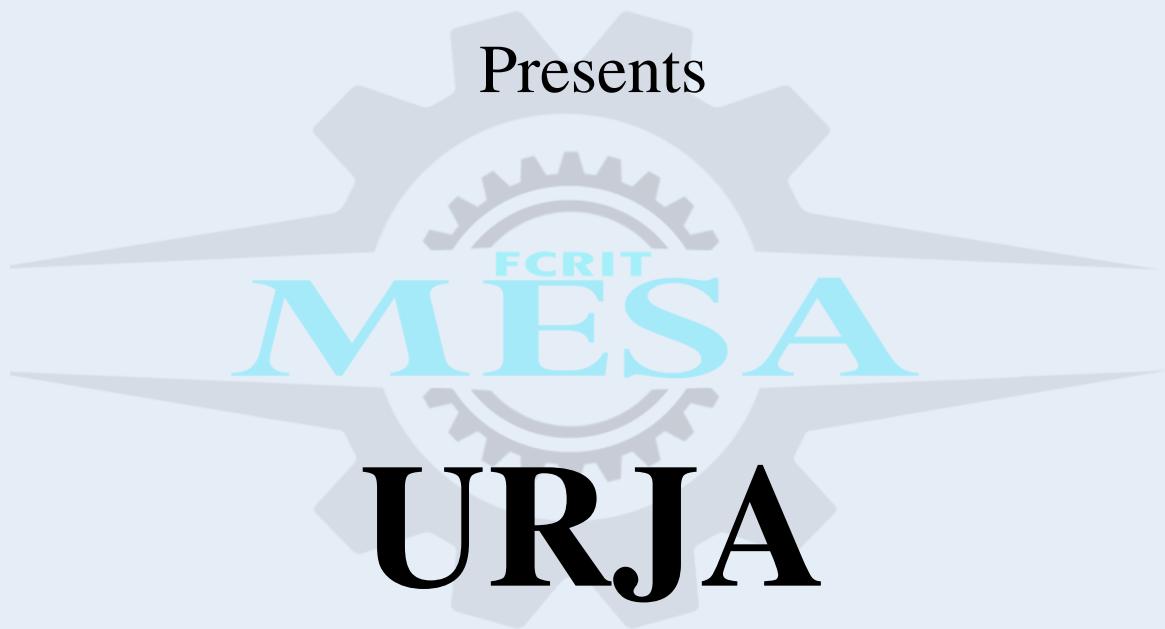

**2021-22**

**MACHINE MIND**

# INSTITUTE PROFILE

F.C.R.I.T. was established in **1994** and is a part of the Agnel Technical Education Complex at Vashi, which itself was established in 1984. The institute is named after late **Rev. Fr. Conceicao Rodrigues**. F.C.R.I.T. persistently seeks and adopts innovative methods to improve the quality of education on a consistent basis. The campus has a cosmopolitan atmosphere with students from all corners of the country. Experienced and learned teachers are strongly encouraged to nurture the students. The global standards set at F.C.R.I.T. in the field of teaching spurs the students in relentless pursuit of excellence. In fact, it has become a way of life for all at the institute. The highly motivated youngsters on the campus are a constant source of pride.

F.C.R.I.T. has, within a short span of time, established itself as a leading engineering college in Mumbai University. Though its reputation rests mainly on the high quality, value-based technical education that it imparts, it has to its credit a verdant, well-maintained Campus and extensive facilities. Its location in the vicinity of the holy places of various religious denominations underscores its secular credentials and its philosophy of "**Vasudhaiva Kuttumbakam**".



# INSTITUTE VISION

To evolve and flourish as a progressive centre for modern technical education, stirring creativity in every student leading to self-sustainable professionals, through holistic development; nurtured by strength and legitimate pride of Indian values and ethics.

# INSTITUTE MISSION

- I. To provide industry-oriented quality education.
- II. To provide holistic environment for overall personal development.
- III. To foster relationship with other institute of repute, alumni and industry.

# VISION OF DEPARTMENT

To provide a vibrant academic, research and industrial environment for creating self-sustainable professionals and responsible citizens.

# MISSION OF DEPARTMENT

- To provide state-of-the-art infrastructure and quality education.
- To generate opportunities for students to provide Industrial Exposure.
- To imbibe team spirit and entrepreneurial skills.

# PROGRAM EDUCATIONAL OBJECTIVES (PEO)

Graduates will...

- Be able to use effectively engineering knowledge and modern tools in the field of core Mechanical Engineering.
- Have interdisciplinary competence in areas like Mechatronics and CAD/CAM/CAE.
- Be able to demonstrate adequate competency and creativity to take up corporate challenges.
- Be able to pursue higher studies and entrepreneurship.

# PROGRAM SPECIFIC OUTCOMES (PSO)

Graduates will be able to...

- Apply knowledge in the domain of Design, Thermal and Manufacturing sciences to solve Engineering Problems.
- Use appropriate tools and techniques to solve problems in the field of Mechanical Vibration and CAD/CAM/CAE.

# PRINCIPAL'S MESSAGE



I intently believe that you should have an all-round development of your personality, having ambitions and aims untrammelled and hard work, enthusiasm, resilience laced with knowledge and intellect which will take you to any extent you desire. Make it a habit to read newspapers daily and ensure the optimum use of library. In today's world, professional approach towards things is necessary. Understanding the basics, relating them to real world situations and then building them into bigger things will help you to become a better engineer. Time management is another asset in the fervent stride for success.

Endeavour to be a better human being while foraying in the competitive life, realizing your dreams, honesty and integrity should be your second names. The college life provides the opportunity to develop one's personality to the fullest extent. The college magazine not only harnesses the skill of writing in the students but also inculcates the pleasure of reading among them.

**- Dr. S. M. Khot**

# HOD'S MESSAGE



Mechanical Engineering is one of the broadest engineering disciplines, offering students a wide range of career options and always remains at the center of all technological advancements. Due to the technological advancement in the engineering field in general, the role of a mechanical engineer is changing rapidly. To meet the ever-changing requirement of the industry and sustain in today's scenario, Mechanical Engineers must have knowledge and skills in multiple domains and multidisciplinary areas to cater the needs of allied industries. There is a need for Mechanical Engineering students to cultivate ideas that allow them to be absorbed in any emerging fields. Each individual can identify the right field for their career and try to develop required skills sets expected by the industry.

I am glad that Mechanical Engineering Students Association (MESA) is doing excellent work. Every year MESA organizes events such as Synergy, MESH, Industrial Visit, URJA (annual magazine) and CALIBRE (National Level Project Competition). These events help students to get acquainted with the latest trends in industries and research. I would like to congratulate the magazine committee for selecting the right theme for Urja Magazine and publishing it.

**- Dr. Nilaj Deshmukh**

# COORDINATOR'S MESSAGE



MESA is a collegiate organization which stands for Mechanical Engineering Students Association. The objective of MESA is to create opportunities for students to enhance their knowledge about the latest developments in the technological world, by organizing various events. The MESA council of F.C.R.I.T., Vashi has ensured a continuous flow of ideas and knowledge by conducting seminars every year. These seminars give the students a sneak peak in the outside world. SYNERGY and MESH are the two events conducted every year under the aegis of MESA. In SYNERGY, one industry is identified during the year and is invited to the campus for interaction. The aim is to bridge the gap between industry and institute and provide an opportunity for staff and students to directly interact with them.

During MESH, a seminar lecture series is organized in which expert speakers from industry and academia such as BARC, IIT etc. are invited to deliver lecture in their area of expertise. A project poster presentation is also organized wherein the final year students display their projects and present posters of their respective projects. Students of lower semesters get an opportunity to have a glimpse of the type of project being carried by final year students. Apart from these activities, MESA also publishes an annual magazine on various technological topics. The published articles are related to researches and inventions that many are unaware of and might be interested in. MESA continuously works for the overall development of the personality of the student other than their academic responsibilities. MESA provides wings and sky to the mind which are planning to fly high and believe in wellness in work.

**- MESA Coordinator**

# TABLE OF CONTENT

ABOUT MESA.....	1
SENIOR COUNCIL 2021-22.....	2
SENIOR COUNCIL 2022-23.....	3
JUNIOR COUNCIL 2022-23.....	4
GENERATIVE DESIGN AI'S WAY TO OPTIMIZE DESIGN.....	5
AI- THE TOMORROW TECHNOLOGY.....	7
INTELLIGENT MATERIAL WITH ARTIFICIAL INTELLIGENCE.....	10
AI IN TRAFFIC MANAGEMENT.....	12
ARTIFICIAL NEURAL NETWORK.....	14
ARTIFICIAL NEURAL NETWORK FOR CFD.....	16
AI AND FUTURE OF MACHINE DESIGN.....	18
CREATIVE CORNER.....	20
STUDENTS' ACHIEVEMENTS.....	38
FACULTY ACHIEVEMENTS.....	42
PLACEMENT DATA.....	44
LIST OF TOPPERS.....	45
SYNERGY 2021.....	46
PRESIDENT'S NOTE (2021-22).....	47
PRESIDENT'S NOTE (2022-23).....	48
ISHRAE COLLEGIATE CHAPTER.....	49
SAE COLLEGIATE CHAPTER.....	52
BAJA INDIA.....	54
AERO FCRIT.....	55
CVS INDIA.....	56
FACULTY PROFILE.....	57



# ABOUT MESA

MECHANICAL ENGINEERING STUDENTS' ASSOCIATION popularly called MESA is a collegiate organization that relates the activities under the Mechanical Engineering Department. MESA is among the most active student bodies in the institute. Mentored by experienced and proficient faculty members of the Mechanical Engineering department, students take upon many initiatives that prepare them to face the challenge of the future. MESA aims to create opportunities for the students to enhance their knowledge about the latest developments in the ever-evolving technological world by organizing various events. SYNERGY is one of the many esteemed events conducted every year as a part of activities under MESA. SYNERGY is conducted in the odd semester every year these events provide a broader vision to the students regarding various technologies and developments happening in the professional field outside the college classrooms. Speakers were invited to deliver lectures for Mechanical Engineering students. The Institution of Engineers (India), Belapur had taken the initiative to inculcate creative thinking and an innovative mindset amongst the students. It was an enlightening experience.

MESA has organized a technical fest called CALIBRE four times in a row in March 2018,2019,2020 and 2021. CALIBRE 2K21 was organized in association with “The Institution of Engineers (India), Belapur Local Centre” with huge success.

## Functions of MESA

- Promoting the interests of students in various technical areas pertaining to mechanical engineering.
- To promote interaction between academia and industry by organising industrial visits, special lectures, and intellectual talks.
- Interacting with other technical societies, within and outside the institute to promote the flow of knowledge and interest.
- To allow students to learn and focus on the cutting-edge technology by presenting it to the students in interesting manner through seminars and workshops.



# MESA COUNCIL

## SENIOR COUNCIL 2021-22



**Adithya Basker**  
President

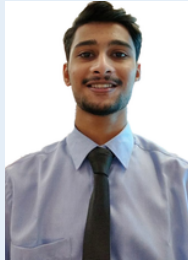

**Malcolm Dias**  
Secretary

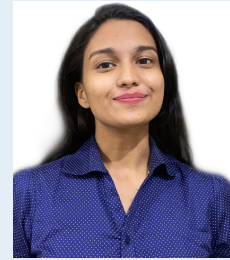

**Aditi Shinde**  
Joint-Secretary



**Natesh Shetty**  
PRO

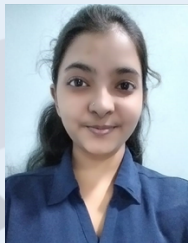

**Pratiksha Pawar**  
Sponsorship Committee



**Pratham Kumbhar**  
Sponsorship Committee



**Shreya Dhopeskar**  
Sponsorship Committee

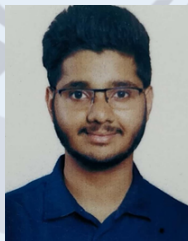

**Omkar Parkar**  
Magazine Committee



**Yash Chaudhary**  
Magazine Committee



**Shriyans Murari**  
Magazine Committee

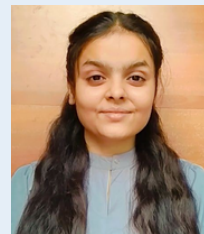

**Ritu Khimasiya**  
Magazine Committee

# MESA COUNCIL

SENIOR COUNCIL 2022-23



**Leon Benjamin**  
President

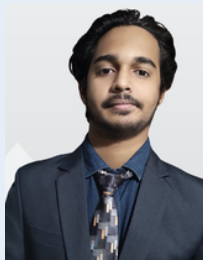

**Jatin satyam**  
Secretary



**Faaiz Nakhwa**  
Joint-Secretary



**Shreya Patil**  
Treasurer



**Monish Bafna**  
PRO



**Atharva Bapat**  
Sponsorship Committee



**Pradnya Bokade**  
Sponsorship Committee



**Vedant Gujarathi**  
Sponsorship Committee



**Rushikesh Garad**  
Magazine Committee



**Rupesh Chaudhari**  
Magazine Committee



**Tazeen Patel**  
Magazine Committee



**Pratham Ukirde**  
Magazine Committee

# MESA COUNCIL

JUNIOUR COUNCIL 2022-23



**Athul Krishna.T.B**  
Member



**Neil.R.Pereira**  
Member



**Hiruthik**  
Member



**Anuj Kabra**  
Member



**Dhananjay Khairnar**  
Member



**Aayush Pankaj**  
Member

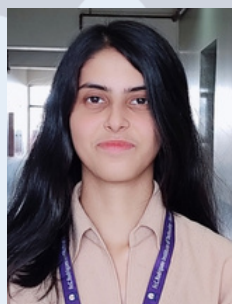

**Ananya Sastry**  
Member

# GENERATIVE DESIGN AI'S WAY TO OPTIMIZE DESIGN

RUPESH CHOUDHARI (MECH V-A)

## I. INTRODUCTION

Design is a vital part of the human being as a whole. From the beginning, designing helped humans to thrive by giving them the ability to convert conceptual tools & devices into reality. As the human tendency to extract most out of any device ignited thus, the concept of iterative design comes into action. That paved the way for generative design. In iterative design, the designer needs to be aware of all the parameters, and constraints. Based on that & designer's imagination the design is done. However, in generative design, the whole process of creating possible designs is done by the AI algorithm in the computer. By just giving the constraints & parameters numerous possible solutions for the specific problem provided by the AI.

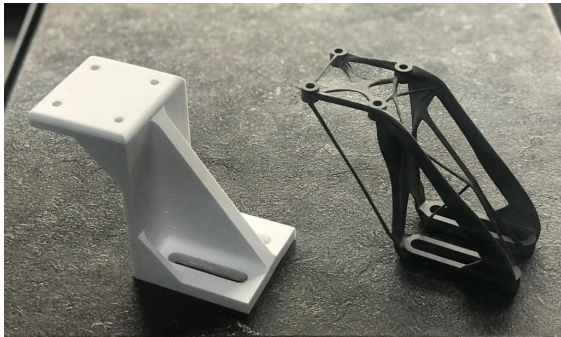

Fig. 1. Generative Design Example [1]

## II. GENERATIVE DESIGN

Celestino Soddu is a renowned architect and professor of Generative Design at the Politecnico di Milano university in Italy. He was the pioneer of Generative Art and Design & first generator software was designed in 1986 to create 3D models of infinite variations.

Generative design is a form of AI that takes an engineering problem to define by the user & presents a wide range of possible solutions to utilize. These designs can be further refined by the user. Generative design is a very effective way to create products with specified constraints and parameters. The algorithm explores all the possible changes that can be done to the specific design to keep it well within the specified parameters. In simple words, Generative design is an Exploration process done by the algorithm to fulfil the given conditions. This is the first time in CAD that a computer is actively aiding the designer to design. Generative design is possible due to cloud computing, It requires a lot of computational power, To solve the numerical to get any

possible solution.

- Generative design works with constraints that include:
  - Materials,
  - Agility,
  - Strength,
  - Cost,
  - Performance.

The design generated by the algorithms closely resembles the organic structures. The algorithm was based on the Bone Recreation theory & Tree Branch theories. It gives designs complex curves and is artistically appealing, which makes them blend more with nature & humans. AI takes over the further to iterate that design to its maximum output level. It takes a unique approach like a tree branch. Analyzing each point will propagate in the direction to fulfil the parameters.



Fig. 2. Bone growth / Tree branch algorithm design [1]

## III. PRACTICAL UTILIZATION

Generative design aids in the enhancement of various aspects of design or system. The thought never got into my mind and was brought to life theoretically. Scope of improving increases dramatically. Because of the device or system gets designed around those parameters itself. So, the only thing left to do is, pick the one iteration! which suits your requirements.

- 3 key areas of improvement are,
  - Performance
    - Lightweight structure
    - Topology optimization
  - Cost reduction
    - Reduction in material utilization
    - Accelerated Design timeline
  - Exploration of new concepts.



Fig. 3. Iteration created using a basic design [5]

As any technology goes through a phase of invention, innovation and utilization. The generative design technology is in the rapid innovation phase. It needs to mature. At best it can make its way into simple tasks. Creating massive structures such as Bridges is complicated.

Also, technology has the potential to one day completely be on its own to create new concepts by itself, eradicating the need for design engineers as a whole. The threat lies in the far future but is important to take into count.

Industry 4.0 gets mainstream, and Additive manufacturing also booming. It's a key technology which allowed us to develop theoretical product designs turned into real prototypes. Generative Design was a process limited to computers to explore. Advancements in machining processes open the door for innovation in the field.

However, the merit of the technology obsoletes the demerits. Providing us with designs never seen before. Exploration is the key to human ingenuity it keeps humans, Human!



Fig. 3. Iteration created using a basic design [5]

## REFERENCES

1. redshift.autodesk.com. (n.d.). *What Is Generative Design, and How Can It Be Used in Manufacturing?* [online] Available at: <https://redshift.autodesk.com/articles/what-is-generative-design>.
2. Autodesk.com. (2018). *What is Generative Design | Tools & Software | Autodesk*. [online] Available at: <https://www.autodesk.com/solutions/generative-design>.
3. Saini, H. (n.d.). *What is Generative Design? | AnalyticsSteps*. [online] [www.analyticssteps.com](http://www.analyticssteps.com). Available at: <https://www.analyticssteps.com/blogs/what-generative-design> [Accessed 10 Aug. 2022]
4. SolidFace 3D CAD. (2020). *Generative Design: Definition and Applications - SolidFace 3D*. [online] Available at: <https://solidface.com/generative-design/> [Accessed 10 Aug. 2022].
5. Siemens Digital Industries Software. 2022. *Generative Design | Siemens*. [online] Available at: <https://www.plm.automation.siemens.com/global/en/our-story/glossary/generative-design/27063> [Accessed 5 August 2022].
6. Sheth, S., 2022. *Parametrically designed 'Generico Chair' takes on your weight with half the volume - Yanko Design*. [online] Yanko Design - Modern Industrial Design News. Available at: <https://www.yankodesign.com/2019/01/29/parametrically-designed-generico-chair-takes-on-your-weight-with-half-the-volume/> [Accessed 6 August 2022].

# A.I.-THE TOMORROW TECHNOLOGY

ATHARVA NAIK(MECH B III)

## I.INTRODUCTION

Artificial intelligence (AI) is the ability of machines to replicate or augment human intelligence, such as: B. Reasoning and learning from experience. Artificial intelligence has been used in computer programs for years and is now being applied to many other products and services.

## II.REACTIVE MACHINES

Reactive machines perform basic operations. His A.I. at this level is the easiest. These types respond to some input with some output. No learning. This is the first level of any of his A.I. systems. A machine learning machine that takes a human face as input and outputs a box around the face to identify it as a face is a simple, reactive machine. The model does not store inputs and does not train.

- a static machine learning model is reactive to his machine. Their architecture is the simplest and can be found in his GitHub repository on the web. These models can be easily downloaded, traded, shared, and loaded into developer toolkits.
- Purely reactive machines are the most basic types of Artificial Intelligence.
- Such AI systems do not store memories or past experiences for future actions.
- These machines only focus on current scenarios and react to them as per possible best action.
- IBM's Deep Blue system is an example of reactive machines.
- Google's AlphaGo is also an example of reactive machines

## III.LIMITED MEMORY

Limited storage type refers to AI's ability to store previous data and predictions and use that data to make better predictions. Machine learning architectures are a bit more complicated due to limited memory. The memory required to build each machine learning model is limited, but the model can be deployed as a reactive machine type.

There are mainly three types of machine learning models that achieve this limited memory type.

Reinforcement Learning

These models learn to make better predictions through many cycles of trial and error. This type of model is used to teach computers how to play games such as chess, Go, and DOTA2.

Long Short-Term Memory (LSTM)

Researchers wondered if previous data could help predict the next element of a sequence, especially a language, so they built a model using what is called long-short-term memory. Developed. To predict the next item in the sequence, the LSTM

marks newer information as more important and older information in the past as less important.

Evolutionary Generative Adversarial Networks (E-GAN)

E-GAN has memory, so it evolves with every evolution. Models produce a kind of growing thing. Things that grow don't always follow the same path each time. Since statistics is the mathematics of probability, not the mathematics of accuracy, we have to change course slightly. On modification, the model can find a better way, the path of least resistance. The next generation of models mutates and evolves towards the paths their ancestors accidentally found.

In a way, E-GAN creates a simulation similar to how humans evolved on this planet. All children will have a more extraordinary life than their parents due to perfectly successful reproduction.

Actual Limited Memory Type

Machine learning models are built with limited memory, but deployments are not always.

Limited Storage

The team continuously trains models on new data

AI environments are built to automatically train and update models as they are used and work.

For the machine learning infrastructure to support finite storage types, machine learning must be built into the infrastructure.

Active learning is becoming more and more common in the ML lifecycle. The ML active learning cycle consists of 6 steps of his

training data. ML models need data to train on. Create a

ML model. A model is created.

model predictions. The model makes predictions and gives

feedback. The model receives feedback on predictions from human or environmental stimuli.

Feedback becomes data. Feedback is sent back to the data repository.

Repeat step 1ta for a short period of time.

These machines can use stored data for a limited time period only

Limited memory machines can store past experiences or someday.

Self-driving cars are one of the best examples of Limited Memory systems. These cars can store the recent speed of nearby cars, the distance of other cars, the speed limit, and other information to navigate the road.

## IV.THEORY OF MIND

We have not yet reached the artificial intelligence type of theory of mind. These are only in the early stages and can be seen in things like self-driving cars. In this kind of A.I., the A.I. begins interacting with the thoughts and feelings of the person. Currently, machine learning models do a lot for humans aimed at accomplishing tasks. The current model has a one-way relationship with A.I. Alexa and Siri obeying all commands. When I yelled at Google Maps to point me in another direction, there was no emotional support and I was told, "This is the fastest way. Instead, Google Maps showed me the same traffic

report and ETA that I was already seeing. Keep giving back, I don't care about your pain

Theory of Mind AI should understand human emotions, people, and beliefs, and be able to interact socially like humans.

This type of AI machine is still not developed, but researchers are making lots of efforts and improvements in developing such AI machines

## V. SELF-AWARE

Finally, in the distant future, perhaps A.I. nirvana will be reached. It makes you confident. Only these A.I. stories inspire the audience with both tremendous hope and fear, as stories often do. A self-aware intelligence beyond humans has an independent intelligence, perhaps people need to negotiate terms with the entities it creates. What happens, for better or worse, is anyone's guess.

Self-aware AI is the future of Artificial Intelligence. These machines will be super intelligent and will have their own consciousness, sentiments, and self-awareness.

These machines will be smarter than the human mind.

Self-Awareness AI does not exist in reality still and it is a hypothetical concept.

## VI. The Future of IT and Artificial Intelligence

. Artificial intelligence (AI) has become an important aspect of the future. This is equally true for information technology (IT) and many other industries that depend on it. Just ten years ago, AI technology seemed like something out of science fiction. Today, we use it subconsciously in our daily lives, from intelligence research to facial recognition, voice recognition, and automation.

AI and machine learning (M.L.) have taken over traditional computing methods, transforming the way many industries operate and conduct day-to-day business. From research and manufacturing to modernizing the financial and medical streams, cutting-edge AI has transformed everything in a relatively short period of time.

AI and related technologies have had a positive impact on the functioning of the IT sector. Simply put, artificial intelligence is a branch of computer science that aims to transform a computer into an intelligent machine without direct human intervention. Using computational training and advanced algorithms, AI and machine learning can be used to create systems that mimic human behavior, provide solutions to difficult and complex problems, and advance simulations to mimic humans. You can become a level AI., the AI market is expected to reach \$190 billion by 2025. By 2021, global

spending on cognitive and AI systems will reach \$57.6 billion, and 75% of enterprise applications will use AI technology. In terms of national GDP, AI is expected to increase China by 26.1% and the United States by 14.5% by 2030.

Nearly 83% of local businesses say AI is a strategic priority, and 31% of creative, marketing and IT professionals plan to

invest in AI technology in the next 12 months. Similarly, nearly 61% of businesspeople cite AI and machine learning as key data initiatives in the next year. In addition, about 95% of managers with experience in handling big data also use AI technology.

The Impact of AI on Information Technology

The digital transformation and industry adoption of AI technology has brought new advances to solve and optimize many of the major challenges of the IT industry. Among all technical applications, AI is at the heart of development in almost every industry, and information technology is one of the first. Integration of AI systems and W.T. It helped ease the burden on developers by improving efficiency, increasing productivity, and ensuring quality. Where the development and deployment of large-scale IT systems were nearly impossible, the development of advanced algorithmic capabilities with AI has made it possible.

A Safer System

Data security is paramount when it comes to protecting personal, financial, and other sensitive information. Government and private organizations store large amounts of customer and strategic data that must be kept secure at all times. Using advanced algorithms and leveraging machine learning, artificial intelligence can provide the necessary level of protection and create an advanced security layer for all these systems. AI can help identify potential threats and data breaches, and provide the solutions and safeguards needed to avoid existing system gaps.

Increased Coding Productivity

Artificial intelligence also uses a set of algorithms to help programmers find and fix bugs in software and create code. Several forms of artificial intelligence have been developed and offered coding suggestions. This increased efficiency and productivity and provided developers with clean, error-free code.

By looking at code structure, AI systems can make useful suggestions that not only improve overall productivity but also help reduce downtime during the production process.

Increased Automation The main advantage of

automation is that it can perform a lot of "leg work" with minimal or no human intervention. By using deep learning applications, IT departments can greatly contribute to automating back-end processes. This enables various cost reductions and minimizes the man-hours spent on them. Many AI-powered methods also improve over time as algorithms learn from mistakes and improve their effectiveness.

Improving Application Delivery During Software Development

When we talk about controlling application delivery, we need to consider the different phases that go into software development. This means that software version control is important and very beneficial during the development stage. And since AI is all about predicting potential problems, it has become an essential and very useful tool for identifying and predicting problems at this stage. So, these can be avoided and/or fixed without major problems. This means developers don't have to wait until the final stages before improving the overall performance of their apps.

Improved Quality Assurance

A large part of quality assurance is ensuring that the right tools are used throughout the development cycle. In other words, AI



methods help software developers use the right tools to fix various bugs and issues in their applications and adjust them automatically during the development cycle.

#### Server Optimization Improvements

Hosting servers are flooded with millions of requests every day. In either case, the server should open her web page as requested by the user. Due to the constant stream of requests, some servers may become unresponsive and slow down over time. AI can help optimize hosted services to improve customer service and improve overall operations. As IT needs evolve, AI is increasingly being used to consolidate these IT workforce requirements and integrate current business and technology capabilities more seamlessly.

#### Should businesses implement AI?

There are many ways organizations can integrate artificial intelligence into their operations. One of the most common reasons is business process optimization. For example, you can use AI to send automated reminders to departments, team members, and clients. It can also be used to monitor network traffic and perform various mundane and repetitive tasks that would otherwise take a lot of time. This gives you the time and energy to focus on the more important aspects of your business. Another advantage for companies looking to implement AI is the personalized customer experience it can provide. This includes everything from recommendations to answering questions to helping users find products. Companies can also use AI to compile large amounts of data. This can lead to strategic insights and business intelligence that could not have been discovered otherwise.

- In fact, nearly 84% of companies say AI can help them gain and/or maintain a competitive advantage. Similarly, about 75% of companies believe the technology will enable them to enter new businesses and ventures. Additionally, nearly 80% of technology leaders see AI as a way to increase productivity and create new jobs. Additionally, nearly 79% of executives say artificial intelligence will make their jobs easier and more efficient, and 36% say that giving employees more time for more creative tasks is a priority. thinking about it.

For many companies, however, the prospect of implementing AI may seem daunting and unfamiliar. In fact, about 37% of executives say the main obstacle to implementing AI in their organization is managers' lack of understanding of how the new technology works. Fortunately, combining artificial intelligence with your IT department makes integration much easier. References

#### REFERENCES

1. [HTTPS://WWW.JAVATPOINT.COM/TYPES-OF-ARTIFICIAL-INTELLIGENCE](https://www.javatpoint.com/types-of-artificial-intelligence)
2. [HTTPS://WWW.MYCOMPUTERCAREER.EDU](https://www.mycomputercareer.edu)
3. [HTTPS://WWW.BMC.COM/BLOGS/ARTIFICIAL-INTELLIGENCE-TYPES](https://www.bmc.com/blogs/artificial-intelligence-types)
4. [HTTPS://WWW.FORBES.COM/SITES/COGNITIVEWORLD/2019/06/19/7-TYPES-OF-ARTIFICIAL-INTELLIGENCE/](https://www.forbes.com/sites/cognitiveworld/2019/06/19/7-types-of-artificial-intelligence/)

# INTELLIGENT MATERIALS WITH ARTIFICIAL INTELLIGENCE

SHRIYANS MURARI (MECH VII-A)

## I. INTRODUCTION

A new industrial revolution known as "Industry 4.0" is characterized by the integration of information technology and modern manufacturing processes. Due to these advanced data collection tools, manufacturing processes are now more intelligent and utilize smart materials (SMs). The characteristics of SMs make them extremely desirable for a wide range of biomedical applications. Numerous practical uses exist for materials with precise microstructure design, including those in transportation, building, and the energy transition. We need to understand a lot about the behavior of these high-tech materials if we wish to use them. To get this information, lengthy tests are typically set up. This strategy, however, is not only extremely expensive but also harmful to the environment. Artificial intelligence (AI) integration enables them to be employed successfully in the construction of novel biomedical platforms to address flaws in the current biotechnology sector. Smart materials (SMs) are excellent candidates for use in a range of applications due to their sensitivity, which allows them to respond to stress, temperature, pressure, light, magnetic, or

electric stimuli. As biotechnology advances scientifically and technologically, the use of SMs will increase. Innovative smart biomaterials are being created at a rapid rate for use in drug delivery, bone regeneration, diagnostic equipment, and wound healing. Machine learning and artificial intelligence are heavily utilized in the development and manufacture of SM-integrated devices connected to the Internet of Things (AI). Utilizing AI assisted systems, which can learn from training datasets without being particularly created, is essential for enabling quick, simple, and autonomous production. INTERNET OF THINGS (IoT)

## II. PATHWAY TOWARDS MATERIAL INTELLIGENCE

The first step in the creation of SMs is the selection of the material type and its composition, which can be organic/inorganic, biological, and composite, as well as the identification of an appropriate fabrication technique, such as microfabricating and nanofabricating (e.g., laser cutting, chemical etching, and photolithography), in order to obtain various structures, geometries, and shapes. The material is functionalized in the last step using physical and chemical alterations that change how stimulus-sensitive SMs behave. The SM can be distinguished from other materials in terms of transiency (responsiveness to different stimuli), immediacy (immediate response to stimuli), self-actuation (the ability to alter shape), selectivity, and directness of action/reaction thanks to both the degree of "smartness" and the "adaptivity" of the material. Five essential components make up smart design: (1) (Tactile sensing) data acquisition is the process of gathering raw input data; (2) (Sensory nerve) data transmission is the movement of the raw data; (3) (Brain) command and control unit is the process of controlling, managing, and analyzing the ata to produce an output; (4) (Motor nerve) data instruction is the transmission of the output decision; and (5) (Muscle) action devices is the process of acting by activating a control unit.

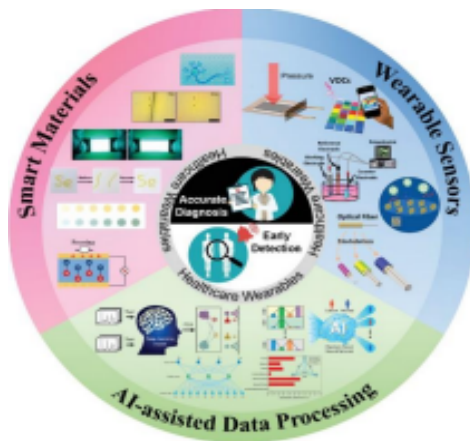

Figure:1 healthcare wearables

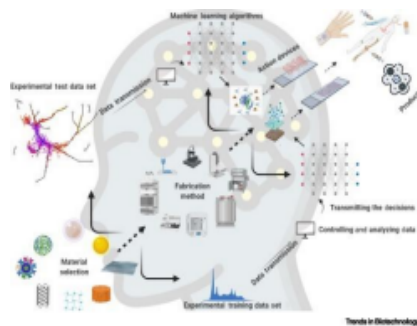

Figure:2- AI Pathway.

### III. AI-ASSISTED DRUG RELEASE DESIGN

The drug-release kinetics of SMs may be impacted by their complex thermomechanical and shape-memory behavior, as well as by their poor fatigue properties. These characteristics can also undermine model predictions. However, using training data based on the kind, size, and structure of the material and drug, material-drug interactions, the type of external stimulant, and other parameters, AI-based algorithms may accurately predict the drug-release behaviors of SMs. To anticipate drug release kinetics, AI-based systems can be trained on the input output relationships found in experimental data. Drug-release modeling-based AI-assisted research have attracted a lot of attention in a variety of disciplines. Using an ANN and a three layered feed-forward backpropagation network, for instance, it was anticipated that increasing temperature (up to 52 °C) at a more basic pH (pH 7) will lead to increased drug release from pH- and temperature-sensitive hydrogels. Compared to the traditional response surface methodology (RSM) model, the AI-based model proved more accurate. The release of doxorubicin from hydrogels under various pH and temperature settings was similarly estimated using the same AI model built on an ANN. The predicted data showed outstanding consistency with the experimental data following data-training with the Levenberg-Marquardt (LM) algorithm optimization approach supported by LS-SVM and SVR. In order to forecast the outcome of drug design and release systems for future medical applications such as cancer therapy, immunotherapy, and bacteriophage therapy, data collected from thousands of trials has been successfully taught in AI systems.

#### REFERENCES

1. <https://www.sciencedirect.com/science/article/pii/S0167779922000051>
2. <https://www.tudelft.nl/en/2021/citg/artificial-intelligence-for-modelling-smart-materials>
3. <https://onlinelibrary.wiley.com/cms/asset/0f44b26b-1c5f4558-9900-37aca373621e/adfm202105482-fig-0001->

# AI IN TRAFFIC MANAGEMENT

YASH CHOUDHARY(MECH VII)

## I. INTRODUCTION

Picture this, you have a very important meeting today. Under no circumstances can you be late. You prepare and leave your home accordingly. You are driving along, only to find cars piled one behind another on an endless freeway that promised to bring down travel time and help your commute. With all the advancements in vehicle technology, if there's no space to drive, it's all futile. Hence, development in traffic management systems is equally important. Traffic management systems are infrastructure elements placed to make sure the traffic flow is uniform and fast. Traffic signals, roundabouts, stop signs, etc. are all traffic management systems. There need to be better systems in place to allow for smoother movement of people and freight. One solution to this is Artificial Intelligence.

## II. VEHICULAR COMMUNICATION

With the wave of cars becoming more technologically advanced, they have more and more capabilities to "communicate". How would you ideally remove traffic? When every vehicle knows where every other vehicle wants to go, traffic will automatically vanish. Vehicular communication systems are computer networks in which vehicles and roadside units are the communicating nodes, providing each other with information, such as safety warnings and traffic information. They can be effective in avoiding accidents and traffic congestion. Vehicular communications is usually developed as a part of intelligent transportation systems (ITS). Every vehicle can coordinate and move accordingly, making traffic flow smooth. This will be made easier with the rise of self-driving cars as they're already equipped with technology to communicate with other vehicles on the road.



Fig 1. Vehicles Communicating on the road [1]

## III. ADAPTIVE TRAFFIC LIGHTS

If vehicles communicating on the road and taking decisions on their own feels far-fetched right now, it is because it is. We are still working on self-driving vehicles and it is still a long way into the phase of commercial adaptation.

So, how can we use AI to improve traffic flow today, we can improve upon existing traffic management systems. The main one being traffic lights. Traffic lights use timers and other tools to keep things running smoothly. However, that is no longer the case. Today, traffic lights are run by computers. This change was made in order to make things more efficient. It allows for better control over the timing of traffic lights. [2]

Adaptive Traffic Control System adapts to real time traffic patterns to optimize the traffic flow by dynamically changing the green split timings. ATCS algorithm adjusts traffic signal timings continuously based on the traffic demand at the intersections and anticipated arrivals from adjacent intersections. It Improves travel time substantially by progressively moving vehicles through green lights and reduces congestion by creating smoother flow. Unlike existing models, Efftronics Adaptive Traffic Control System (ATCS) considers developing countries' traffic scenarios, vehicular movements and responds in real time. It uses downstream detection and provides a user -friendly interface to support day-to-day operation. Traffic data from junctions is consolidated in a central traffic system and Adaptive Traffic Control System (ATCS) algorithm determines optimized red-green phases of traffic signals in order to achieve junctions green-green synchronization across the entire region of deployment. ATCS dynamically adapts to changing traffic conditions in real time. ATCS uses machine learning algorithms to analyze real-time traffic data from vehicle detectors to determine signal timings that are optimal for existing traffic conditions. The duration of traffic signal's red-green phases and green waves is automatically changed every cycle by examining the traffic conditions at intersections along the corridors or entire region of deployment. [3]



Fig 2. Adaptive Traffic Lights in Operation [2]

#### IV. TRAFFIC FORECASTING

So now that we saw adaptive traffic lights, let's look at another aspect of traffic flow management. This is being implemented on some level by Google Maps and that is traffic forecasting. Imagine a program, which can predict traffic hotspots based on current and previous data and deter traffic to other routes so as to make sure that one location does not bottleneck. This is where Machine Learning, a branch of AI, comes in.

Machine learning (ML) allows you to create predictive models that consider large masses of heterogeneous data from different sources. Numerous studies have been conducted on the application of ML algorithms to forecast road traffic. Here are some successful examples.

The random forest algorithm creates multiple decision trees and merges their data to obtain accurate predictions. It's quite fast and can produce effective results given sufficient training data. When applied to the road congestion problem, this method showed an accuracy of 87.5 percent. In this case, weather conditions, time period, special conditions of the road, road quality, and holidays are used as model input variables.

The k-nearest neighbors (KNN) algorithm relies on the principle of feature similarity to predict future values. Experiments with the KNN model demonstrated over 90 percent accuracy of short-term traffic flow prediction. [4]



Fig 3. Congestion Prediction based on data analytics [3]

#### V. CONCLUSION

Just a few of theoretically unlimited ideas for traffic management were discussed in this article. Artificial Intelligence is just one means for better traffic flow. These systems can be integrated with the existing CCTV & Traffic Control system to provide a holistic solution towards preventing the current traffic menace. Not only this, various AI-based traffic analytics can be deployed over existing Traffic enforcement and surveillance system also, with minor tweaking & adjustments, resulting in a highly optimized solution at a lower cost to the public exchequer.

Hence, in today's scenario, an Integrated & Intelligent Traffic Management system is surely a big idea, for not only improving traffic on urban roads & reducing mental agony of commuters but also SAVE HUMAN LIVES due to road fatalities. [5]

#### REFERENCES

1. [Vehicular communication systems - Wikipedia](#)
2. [AI in Traffic Management: Artificial Intelligence solves traffic control issues \(clickworker.com\)](#)
3. [Adaptive Traffic Control | Intelligent Traffic Control | Efftronics](#)
4. [Traffic Prediction with Machine Learning: How to Forecast Congestions | AltexSoft](#)
5. [How AI traffic management can help unclog urban roads | The Financial Express](#)

# Artificial Neural Network for Thermal Science Engineering

BANIZ ANTONY MICHAEL (MECH VII - A)

## I. INTRODUCTION

Artificial intelligence approaches have long been used in a range of real-world applications. However, it is only recently that such techniques have been applied to thermal science and engineering. This focus is mostly attributable to the unique requirements and needs of the field of thermal science and engineering (TSE), which are a result of its growing complexity and the realization that it is impractical to handle many important problems in this area using conventional analysis. The goal of this brief overview is to highlight recent developments in artificial intelligence (AI) and the applications of these approaches to contemporary issues in thermal science and engineering. There will also be some shortcomings and potential for future uses.

## II. Background

Today, artificial neural networks (ANN) are without a doubt the most effective AI approach for TSE applications. One explanation is the availability and existence of several input-output data sets for TSE phenomena and devices. The parameter space's input data are the output data, which are the desired heat transfer and other performance outcomes. Since it is widely acknowledged that the intricacy of real-world TSE problems continues to make the construction of workable theoretical models impossible, the accompanying experimental data are instead continuously generated and empirically correlated for use in applications. As was previously mentioned, these data are typically chaotic because of different experimental and statistical uncertainties. The ANN analysis can withstand them well, and other features are also highly desired. The network can recognize and learn complicated and highly nonlinear input-output relations thanks to its built-in extremely parallel data processing capability. Additionally, the network can well tolerate errors thanks to the vast number of processing units. In order to enhance its learning process, the ANN can also dynamically adapt and modify the network structure.

## III. ARTIFICIAL NEURAL NETWORK IN THERMAL ENGINEERING

A quick survey of the kinds of TSE concerns that the ANN methodology has specifically addressed, all with excellent outcomes. As previously indicated, the application of ANN analysis to TSE applications is very new. Its use in TSE began roughly in the early to mid-1990s, and interest in it seems to

and ANN application in the broad field of energy engineering, have risen steadily since then. Reviews of the literature have also been published recently. The most thorough assessment, which addresses both the creation of the ANN technique, which involves static and dynamic modelling and dynamic control, was written by Sen and Yang and published in 2000 [1]. The review specifically cited and discussed particular categories of TSE applications, including heat transfer in convection and conduction, heat exchanger performance, HVAC performance and control, thermodynamic property prediction, thermal storage and fluidized-bed system performance, materials processing in microelectronic manufacturing, thermal placement in power electronics, rapid thermal processing control, and thermal image processing analysis. These reviewers also identified TSE applications in the same review where the ANN method might have a big impact. The domains with the greatest effects in this regard are those where the absence of physical models, high system complexity, and lack of characteristics or constitutive relations pose significant obstacles to the field's growth. This is especially important in regions with big experimental data bases for network training. Thermal networks, the processing of thermal materials, environmental and safety studies, tribology systems, reactive systems, multiphase systems, thermal inverse problems, and parameter estimation are a few examples of TSEs that are useful.

There are also newer reviews for select TSE apps accessible. In the field of solar steam generators, solar radiation, HVAC systems, supermarket refrigeration, and power-demand management in power systems, the review of Kalogirou focuses on specific applications of ANN analysis. Three specific cases of industrial processes with control are discussed in the reviews by Ward et al. [3]; these cases are heat transfer during spray cooling, emission production from pulverized coal combustion, and transient performance of a steel reheating furnace. In their more recent review, Sen and Yang [4], they specifically address multiphase flow with heat transfer, flow- regime identification, multiphase flow in columns, towers, and packed beds, heat transfer in evaporators, boiling heat transfer in liquid mixtures, heat transfer in manufacturing processes, and thermal processing of foods. The ability of the clustering capability of the ANN analysis to accurately predict two-phase flow regimes is particularly noteworthy; this capability will be mentioned once more in a later example. This is because such identification must be established a priori before the proper correlation results can be applied.

## IV. INTERNAL MODEL CONTROL

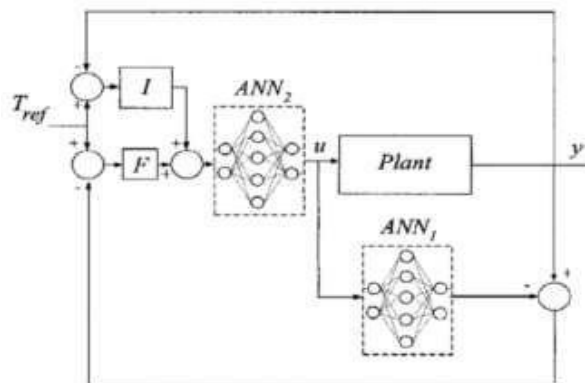

Here, the emphasis is on the ANN's on-line adaptation for best performance, and it is trained as it does its control role. The idea behind the IMC, which is roughly depicted in Figure 1, is to run a real system alongside an ANN plant model for the heat exchanger system called ANN1. The neurocontroller, ANN2, positioned in the forward route of the control scheme, receives feedback from the difference between the output of the real system and the model

Fig. 1. Neural controller-based IMC [6]

## V. CONCLUSION

Overall, despite the numerous uncertain parameter choices in the ANN approach, as already discussed earlier, the findings of all the research using ANN analysis mentioned above are all extremely good. All of these examples, though, focus on particular issues, and while they are all very encouraging, their outcomes may not always translate to other new TSE issues. It is necessary to approach this problem in a series of systematic experiments to address progressively difficult applications in order to identify, if any, any flaws in the ANN methodology that would warrant further research.

## References

1. Sen, M. and Yang, K. T., 1999-2000, Applications of artificial neural networks and genetic algorithms in thermal engineering, in CRC Handbook of Thermal Engineering, 4.620-4.661.
2. Kalogirou, S. A., 1999, Applications of artificial neural network in energy systems-a review, *Ener. Conv. and Manag.* 40, 1073-1087.
3. Ward, J, Wilcox, S. J., Tan, O.H., Tan, C. K., Payne, R. J. and Garwood, D. R., 2001, Simulation of a range of thermal systems by artificial neural networks, *Proc. 2001 ASME IMECE*, Paper IMECE2001/HTD-24284, New York, 7pp.
4. Sen, M. and Yang, K. T., 2003, A review of multiphase flow and heat transfer with artificial neural networks, *Proc. 2003 ASME IMECE*, Washington, DC. 8pp.
5. Kwang-tzu Yang., 2007, Role of Artificial Intelligence (AI) in Thermal Science and Engineering, *Proc. 2007, 2007 ASME-JSME Thermal Engineering Summer Heat Transfer Conference* July 8-12, 2007, Vancouver, British Columbia, Canada

# ARTIFICIAL NEURAL NETWORK FOR CFD

PRATHAM UKIRDE(MECH V)

## I. INTRODUCTION

Efficient use of computational resources and simulation turn-around times are critically important factors behind engineering decisions to expand CFD technology to support more product design. Recent developments in GPU-based high performance computing (HPC) and AI have improved computational speeds by orders of magnitude for a broad range of CFD simulations relevant to engineering practice. This topic will examine an inverse method to the solution of CFD through implementation of artificial neural networks. The CFD solution starts with imaging data and discovers the underlying physics and/or properties of a fluid flow configuration directly from the partial differential equations (PDEs) that describe the flow behavior. This inverse approach can be used for predicting flow velocities and pressures for an entire transient range, without the need for direct measurement of such quantities and promises advances for a wide range of fluid flow applications.

## II. PHYSICS-INFORMED NEURAL NETWORKS

AI research has given rise to applications of physics-informed neural networks (PINNs) that leverage the underlying laws of physics, often described in the form of PDEs, to solve forward, inverse, and model discovery problems. Advantages over traditional methods of solving PDEs relevant to CFD include (i) usability: not requiring arduous meshing, (ii) speed: ability to solve multiple geometries simultaneously, (iii) scalability: embarrassingly parallel across clusters of GPUs, and (iv) expertise: ability to leverage training experience.

NVIDIA has applied PINNs for problems requiring either an inverse approach or a forward solution similar to those available from conventional numerical CFD solvers, for use cases such as the design and optimization of heat sinks for the company's DGX systems powered by the V100 GPU. These networks require no data, can work with single or parameterized geometries and solve single or multiphysics problems. At the backend, GPUs are used for computation of the network training and inference procedures with the cuDNN accelerated TensorFlow deep learning framework.

The concept behind a neural network solver is to approximate the solution to a given PDE and BCs. This is accomplished by formulating a loss for how well a neural network solution satisfies these conditions. For validation of this idea, a lid driven cavity example was investigated as shown in Figure 1.

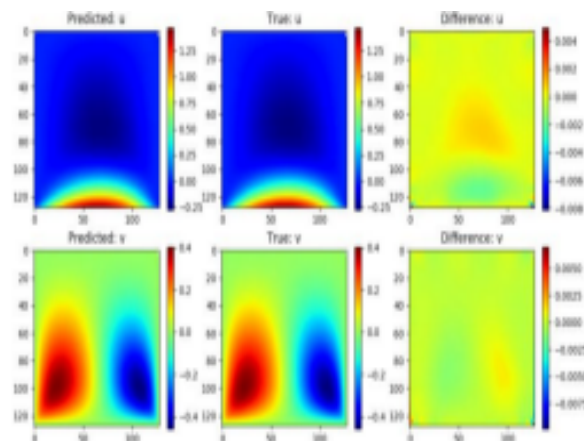

Fig. 1. Validation of PINN Predicted results vs. True by an open source CFD solver, for a lid driven cavity and PINN Predicted thermal results of a typical NVIDIA GPU heat sink design candidate<sup>[3]</sup>.

Results show a forward solution of the PINN approach for the lid driven cavity compares very well with a conventional CFD solver, with errors in the u and v components of velocity being 0.2% and 0.4% respectively<sup>[3]</sup>.

## III. MULTIPHYSICS HEAT SINK

The PINN inverse method described was used to improve the design and effectiveness of heat sink candidates where thousands of configurations could be analyzed within hours as opposed to weeks using conventional CFD simulations. Results are provided in Figure 2, that apply the neural networks solver to heat sink configurations for a multiphysics simulation of both fluid and heat equations with one-way coupling. The left configuration is a simple design with only 3 fins used to benchmark and compare solvers, and the left image shows results for a heat sink design candidate under consideration for next generation DGX servers.

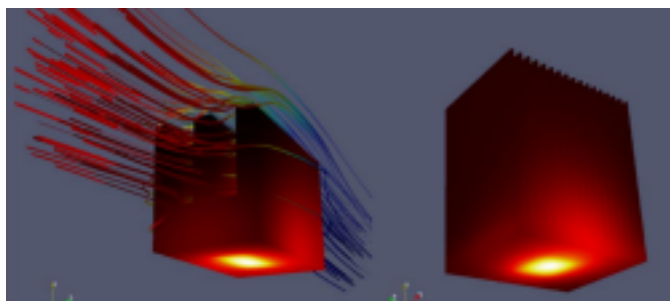

Fig. 2. Heat sink configurations, 3 pin (left) and full design candidate (right)<sup>[3]</sup>



The key physical quantities of interest from the multiphysics simulations are pressure drop and peak temperature. Results for these quantities were calculated using the PINN solver as well as conventional CFD solvers that typically deploy conjugate heat transfer solutions to the multiphysics solution.

Table 1. provides results that compare PINN solver, the OpenFOAM solver ([www.openfoam.com](http://www.openfoam.com)) using the pimpleFoam option, and a commercial CFD solver for the 3 fin heat sink.

Physical Quantity	Neural Network Solver	Open FOAM (pimple Foam)	Commercial CFD Solve
Pressure Drop (Pa)	6.9	7.3	7.3
Peak Temperature (C)	79.8	81.3	80.2

Table 1. Results of numerical consistency for 3 pin heat sink<sup>[3]</sup>.

Table 2. provides comparisons for the design candidate heat sink. For both configurations, the PINN solver shows good agreement and under-predicts results in the ~5% range for the 3 pin configuration, and in the ~10% range for the design configuration.

Physical Quantity	Neural Network Solver	Open FOAM (pimple Foam)	Commercial CFD Solver
Pressure Drop (Pa)	25.6		28.4
Peak Temperature (C)	78.8		84.9

Table 2. Results of numerical consistency for design heat sink<sup>[3]</sup>.

#### IV. HPC CONSIDERATIONS

The number of potential design evaluations for HPC-driven design optimization is most often restricted by the HPC workload that can fit within overall design cycle times. As an example, investigation of 50 dimensional variations for each of just two design parameters, edge fin height and center fin height, result in 2500 design evaluations. The required HPC resources and computational time using conventional CFD simulations is intractable, however the PINN approach offers the possibility to analyze a full spectrum of design candidates in a fraction of the time.

Comparisons of HPC resource requirements between the PINN approach and conventional CFD solutions are shown in Table 3. The neural network requires 5 days of computational time for the training on 1 x V100 GPU for the entire design space. Once completed, a single inference run is only 3 sec for a single evaluation vs. 1 hour for the commercial CFD solver or a factor of 1200x that represents 3 orders of magnitude. There are also dramatic reductions in memory capacity requirements by 296x, and a 4x reduction in output file size to help improve file handling and I/O times for post-processing procedures.

HPC Quantity	Neural Network Solver	Commercial CFD Solver	Factor
Total compute time for 2500 design evaluations	2 hrs* : 3s each on 1 x NVIDIA V100 GPU * Inference time only	104 days: 1h each on 1 x Intel Gold 6128 (SKL) 12 cores @ 3.4 GHz	1200x
Memory capacity (each eval)	0.216 GB	64 GB	296x
Output file size (each eval)	0.5 GB	2 GB	4x

Table 3. HPC resource requirements of PINN solver and commercial CFD solver<sup>[3]</sup>

## V. CONCLUSIONS

As CFD simulation demands increase and motivate the need for more transients, higher resolutions, and multiscale, multiphysics simulations, GPUs will become an essential HPC technology. The AI approach presented has demonstrated substantial benefits to dramatic reductions in CFD turn-around time and other HPC resource requirements that lead the way towards practical HPC-driven design methods. Based on current trends, GPU-based HPC combined with novel AI techniques will enable a level of applied CFD that can grow as a common practice to support engineering design and optimization procedures.

## REFERENCES

1. M. Raissi, P. Perdikaris, and G. E. Karniadakis. "Physics-informed neural networks: A deep learning framework for solving forward and inverse problems involving nonlinear partial differential equations," *Journal of Computational Physics* 378 (2019): 686-707.
2. O. Hennigh, Sukirt, M. Raissi, S. Choudhry, S. Narasimhan, C. Lamb. "Multiphysics Neural Network Solver," NVIDIA GPU Technology Conference, March, 2020, San Jose, CA, USA.
3. O. Hennigh, S. Choudhry and S. Posey. "GPU-Based ANN(Artificial Neural Network) for CFD," NVIDIA GPU Technology Conference, May, 2020, Nice FRANCE.

# AI & THE FUTURE OF MACHINE DESIGN

PRINCETON DSILVA (MECH VII-A),  
RITU KHAMASIYA (Mech VII-A)

## I. INTRODUCTION

AI magic is here to save the world, making us giddy with excitement and terrifying us at the same time. However, AI is still mostly unknown, and figuring out exactly how it will work in the design world is pretty much like trying to figure out how many angels can dance on the head of a pin.

AI (artificial intelligence) has become an over-hyped buzzword across many industries and the design world is no exception. There are ongoing conversations between designers and developers around the future impact of AI, Machine Learning, Deep Learning... VR, AR, and MR (virtual, augmented, and mixed realities), and how our jobs may be changing.

So, what does design bring to the conversation? With AI, new relationships will need to be established between customer and product. These interactions will be just the beginning of the ongoing conversation between business and consumer about what artificial intelligence can, and should be able to do for products and services. Designers will bring the necessary empathetic context for innovation, which is how a business will succeed with AI.

AI holds a lot of potential for the design world, but for this to happen the hype around it needs to be deconstructed. It would be better if designers cleared their minds and didn't think about AI as "artificial intelligence"—as though AI was going to work as some kind of magic-tech. A more useful way to think about AI—at least for the short-term—is "augmented intelligence."

AI is going to be mostly about optimization and speed. Designers working with AI can create designs faster and more cheaply due to the increased speed and efficiency it offers. The power of AI will lie in the speed in which it can analyze vast amounts of data and suggest design adjustments. A designer can then cherry-pick and approve adjustments based on that data. The most effective designs to test can be created expediently, and multiple prototype versions can be A/B tested with users.

## II. OPTIMIZING SEVERAL VARIABLES

The generative design method may sound like something for the far future, but it was recently used to solve a real-world problem involving a part for the Airbus A320 aircraft, one of the most well-known and expensive items in the world. It supported

a flip-down seat for flight attendants during takeoff and landing and served as a divider between the plane's galley and passenger section. The partition's weight and volume had to be decreased by Airbus engineers while still being strong enough to support the weight of flight attendants.<sup>[4]</sup>

Once the design parameters were set, the generative design software (in this case Autodesk Within) cycled through thousands of design variants. The human design team digitally mapped the different generated options against weight, stress, and strength parameters to decide which to prototype.<sup>[4]</sup>

The resulting design is a latticed structure that looks random but is based on mammal bone growth. Like natural bone, the partition is dense at points of stress but lightweight everywhere else. The design, which Airbus and Autodesk call the bionic partition, is 45 percent lighter than the conventionally designed compartment divider found on existing aircraft. Fabricated using additive manufacturing, the finished product requires just one-twentieth the raw material

compared with a partition built using traditional design processes.

Product designers typically have a clear understanding of the outcomes they will get with various materials. But things might soon become difficult when designers must strike a balance between numerous intended outcomes. But things might soon become difficult when designers must strike a balance between numerous intended outcomes. Design teams can quickly iterate through dozens or even millions of distinct potential concepts by relying on AI and ML tools, and then concentrate all of their limited time on those that the algorithms have determined to have the greatest promise.

## III. DAILY LIFE EXAMPLES

Mathematical optimization is already being used to improve on existing structures.

For example, if you want to improve the tensile properties of a door, building, or other structure, you fit a computer model with lots of data about that structure, run the meta-optimization algorithm of choice (genetic algorithms, simulated annealing, ant colony optimization, etc.), and get the newer, improved results.

Topology Design: In Autodesk Fusion 360, it controls the design load parameters. An example of network topology is a water-distribution application that traces the flow of water from a pumping station to residences. A street network is another example. For network topologies, you can specify the direction

for a link and specify the resistance for a link or node.

Relevant research in engineering design knowledge representation serves as a foundation for guiding the adaptation of machine learning techniques. Given the design prototype as the representation paradigm to be learned, a methodology and representation of a training set that considers the design knowledge categories function, structure, and behavior, as well as a technique for learning the associations between these categories, are described, and a technique for learning the associations between these categories is defined. The method is demonstrated by using truss examples to learn generalized truss design principles.<sup>[1]</sup>

Although the specifics vary by programme, a conceptual clustering programme accepts a set of observations as input and outputs a hierarchy of clusters. A cluster is made up of a subset of attribute-value pairs. Each cluster is also defined by the observations stored beneath it, and each cluster contains the observations of all its sub-clusters. When a new observation is introduced, it is accommodated within the existing hierarchy by employing an evaluation function to determine the most appropriate cluster or to introduce a new cluster.<sup>[2]</sup>

The probability associated with each cluster and attribute-value pair is stored in COBWEB; the resulting representation is known as a probabilistic concept. COBWEB performs one of several operators to accommodate new observations, and selects between the available operators using a category utility function.<sup>[2]</sup>

#### IV. CONCLUSION

The applications of ML-based approaches in mechanical property prediction, materials design, and computational methods are summarized, followed by perspectives on opportunities and open challenges in this emerging and exciting field.

#### References

1. .Maher, M. L. "Machine Learning in Engineering Design: Learning Generalized Design Prototypes from Examples." *Development of Knowledge-Based Systems for Engineering*. Springer, Vienna, 1998. 161-181.
2. Alem, Leila, and Mary Lou Maher. "Using conceptual clustering to learn about function, structure and behaviour in design." Diss. INRIA, 1991.
3. <https://asmedigitalcollection.asme.org/memagazine/lect/article/139/10/38/380304/AI-and-the-Future-of-the-Machine>
4. <https://www.machinedesign.com/automation-iiot/article/21164136/4-ways-ai-will-change-design-and-manufacturing>
5. <https://pubs.rsc.org/en/content/articlelanding/2021/mh/d0mh01451f>
6. <https://www.machinedesign.com/automation-iiot/article/21164136/4-ways-ai-will-change-design-and-manufacturing>



# CREATIVE CORNER

**I am innovative.**

**Understands the language of mathematics.  
As well as the scientific methods that are stated,  
With knowledge of thermodynamics.**

**I design parts with AutoCAD,  
Then assemble them together.  
High salary, which is great!  
Hopefully it will last forever.**

**Many various fields.  
So much job opportunities,  
To make objects like titanium shields,  
Or other things to improve our communities**

**Skateboards have seven layers of veneers.  
Trust me, I'm an Engineer!**

**We genuinely hope that you had a wonderful time acquiring  
bits of knowledge from our Engineers Technical Corner.**

**So let's turn the page and have a look at our engineers  
creative corner!**



# Abyss

One day, I wake up all bothered,  
Confusion on my face, all  
smothered. Wondering if this is  
what I want, And that's when I  
hault.

These contrasting thoughts  
I have been thinking lately,  
I am scared of myself  
Can someone come and save me?

I am not fine even if I tell myself I 'll be,  
Because darkness is all that I can see.  
What do I do next?  
Should I panic or take a rest?

I have been eagerly running towards you  
Because I really wanted to.  
But I am telling myself all the lies,  
Making me think otherwise.

I am holding my hand out  
For someone I don't know,  
clearly. I am scared of myself  
Can someone come and save me?

What is happening?  
One time you were my everything.  
My eyes, with tears, they sting,  
Because I can see everything falling.

When I close my eyes  
I feel like I am falling off the skies.  
Now I think this isn't right,  
But it was me who chose to fight.

I have trapped myself  
Into this dark abyss, Is it  
too late for someone To  
come and save me?

**- SAKHI SURANGE (MECH 5B)**

# MISUNDERSTANDING

I am the biggest enemy  
Of love and give rise to rivalry  
I'm completely invisible,  
From where I'd come up is utterly  
Unpredictable.  
I got the talent to destroy  
Years long of relationship you enjoyed.  
I'm the matchstick capable of causing  
Forest fire  
It won't matter if you think I'm a liar.

- PREKSHA DONGRE

MECH-5B

# A RAINY DAY

The dawns are dusky, you can see people drive with their lights on whereas some can see through the dark. The colors of clothes appear darker than the regular day, people are drenched with responsibilities and thoughts that pour upon them. The vicinity seems far away in the folds of white curtains so dark.

Even in the chaos of sandy winds and wet ground one can smell petrichor giving birth to a thousand lives by going down a million miles including a pluviophile. How beautiful, the season makes us realize, the fact of how waterproof our dreams can be and how those lines of rain can never clog the drains and be on time. In those stormy nights so bright the clouds that fled on the mountainous heights washed away all our frights.

Yes, it's a rainy day bringing out the wings so light to see the success's sight even in those doomy lights you know it can shine bright.

- DEVOUSHKA YADAV  
MECH SEM 5 A



# Leap of Faith

Hold my hand,  
And watch me come,  
Spread wings of hope  
and call me out...  
Whether I live or die  
In hope of your sight...  
It's a leap of faith (x2)  
Ahh.. It's a leap of faith  
My thoughts dwell u...  
Let me come through u..  
Souls like serve to be loved  
When all of universe,  
Will grow tired  
Of sending u light,  
I will still burn for you  
I m yours only forever...  
It's a leap of faith (x2)  
With u &without u...  
Some souls are meant to heal  
Some souls are so dead to kill  
You my love,  
Are meant to be filled,  
  
Dark times past me & you,  
Cripple me, hurt you  
Haunt you, hollow me  
Depress you and me...

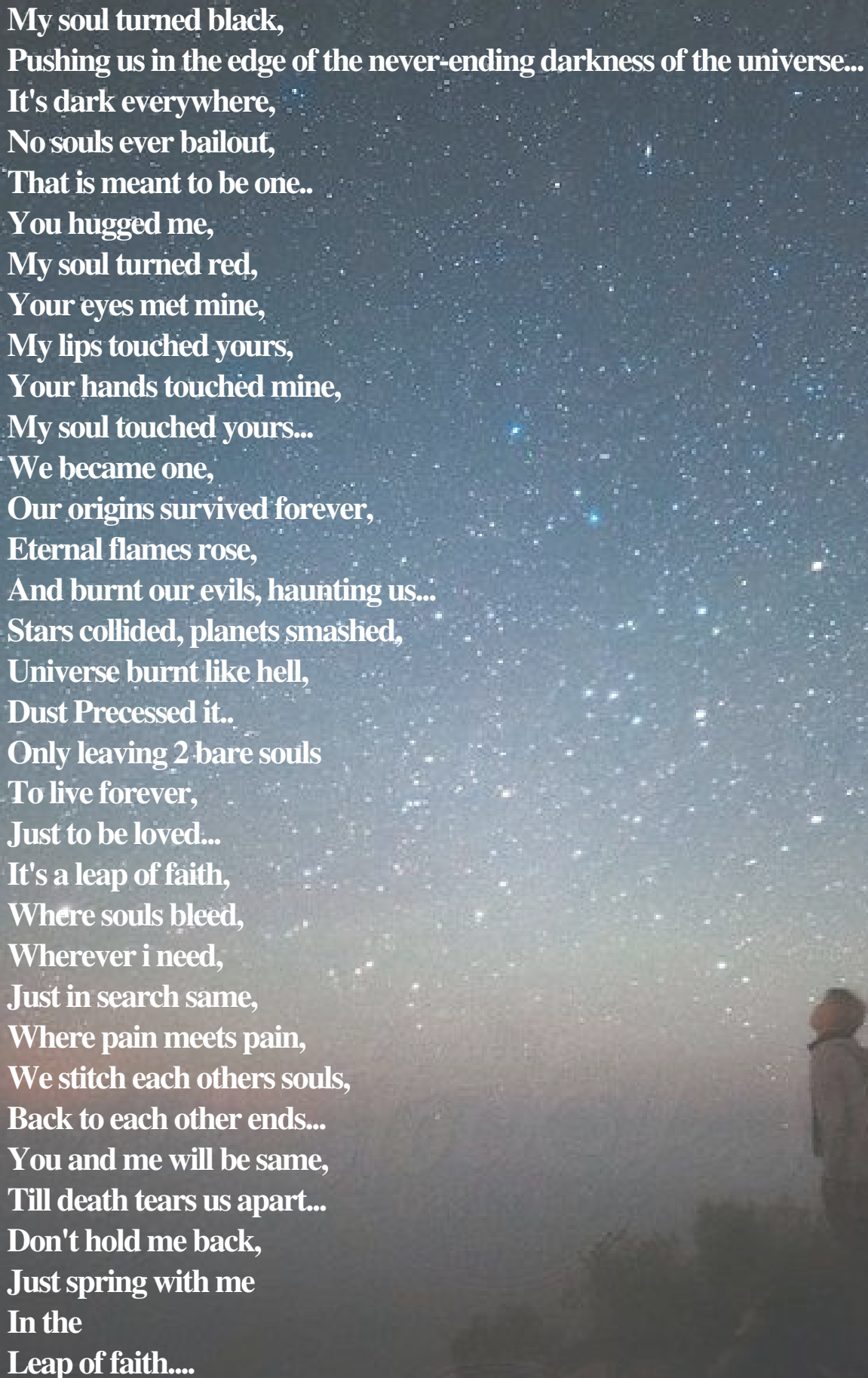
A person is standing in a field, looking up at a vast, starry night sky. The person is silhouetted against the light of the stars. The sky is filled with numerous stars of varying brightness, creating a sense of depth and wonder. The overall mood is contemplative and serene.

My soul turned black,  
Pushing us in the edge of the never-ending darkness of the universe...  
It's dark everywhere,  
No souls ever bailout,  
That is meant to be one..  
You hugged me,  
My soul turned red,  
Your eyes met mine,  
My lips touched yours,  
Your hands touched mine,  
My soul touched yours...  
We became one,  
Our origins survived forever,  
Eternal flames rose,  
And burnt our evils, haunting us...  
Stars collided, planets smashed,  
Universe burnt like hell,  
Dust Precessed it..  
Only leaving 2 bare souls  
To live forever,  
Just to be loved...  
It's a leap of faith,  
Where souls bleed,  
Wherever i need,  
Just in search same,  
Where pain meets pain,  
We stitch each others souls,  
Back to each other ends...  
You and me will be same,  
Till death tears us apart...  
Don't hold me back,  
Just spring with me  
In the  
Leap of faith....

**-PRANAV.G**

**(Dedicated in memory of My beloved frnd SUYASH)..**

# Cycles of Souls

Standing on the porch  
Of deathbeds...  
Graveyards the subtle Society  
Calls it...  
Saw the rise of Enormous  
Souls Vanishing Beyond The  
Clouds of Edons..  
Bare sights of Firm-Seeded  
Individuals Is inexorable to view  
To cherish the moment of Soul waving hands  
Vividly watching his loved ones  
Paying respects and remembering  
His wicked soul...through condolences  
And Tears...

Their standing a small girl  
With her black dress.. Viewing all this from the back of the tree...  
Closest to her was the soul...  
Love, compassion, and bond it shared..  
Living here all alone.. In this  
World of greed and hate...  
The barren soul gave his last kiss  
To forehead and promised to be  
With her.. In corner of her heart  
She sunkissed him...  
And left him.... To see the bright light  
Of vanishing soul...  
Only the purest can see it  
And happiness on her cheeks tells all..  
I suppose it's a romantic place to visit..  
Yet though people see it as the place of death I see.. It  
as the purest first form of the phase of the afterlife gateway  
where  
soul-to-soul interactions have no restrictions...

**Graves of loved ones are the last-first moments of pure love and affection...**

**infinite boundaries of caring,  
it's like the same place where they can cuddle u first..  
When they saw you..**

**They communicate with us with the souly  
Lines.. Only few get the transmission  
To Believe it...**

**Souls die and pave**

**The way for the**

**Pure, white souls**

**To place their feet**

**On this divine Land...**

**In the form of a Dormant Piece**

**Of blossoming Graceland**

**Storing an imminent flow**

**Of memories**

**Buried deep down...**

**Non-sensible me have than unexpected Vision to see it..**

**U may call it inexpensive**

**But in reality it's an illusion to Bear eyes**

**Of pain wrenching Personal...**

**Watching the cycles of the soul**

**Traveling within the hours**

**Of Divinely High rose**

**Abode with long-lasting**

**Immaculate beyond the Lifetime...**

**Wrenched in the trillion possibilities**

**Of life... Just in one lifetime**

**Just stuck in the**

**The cycle of uncousiouness Souls...**

**-PRANAV. G**

**(In the memory of loved ones... Lost to this universe,  
seemingly beamed to live within us.. Just to live another day**

# You

Every night I think about you,  
I know lots of people but I still want you  
I wanna stick to you like a glue,  
But baby our life seems to be dark as blue  
I miss those days when I used to be with you.  
I have held back my tears for over many months  
I always had a fear of losing you,  
but you didn't even care about me.  
I always think about you.  
And I lost my mind dreaming about you.  
I searched for my love but  
I couldn't find you.

**-ENGINEER  
MECH -5A**

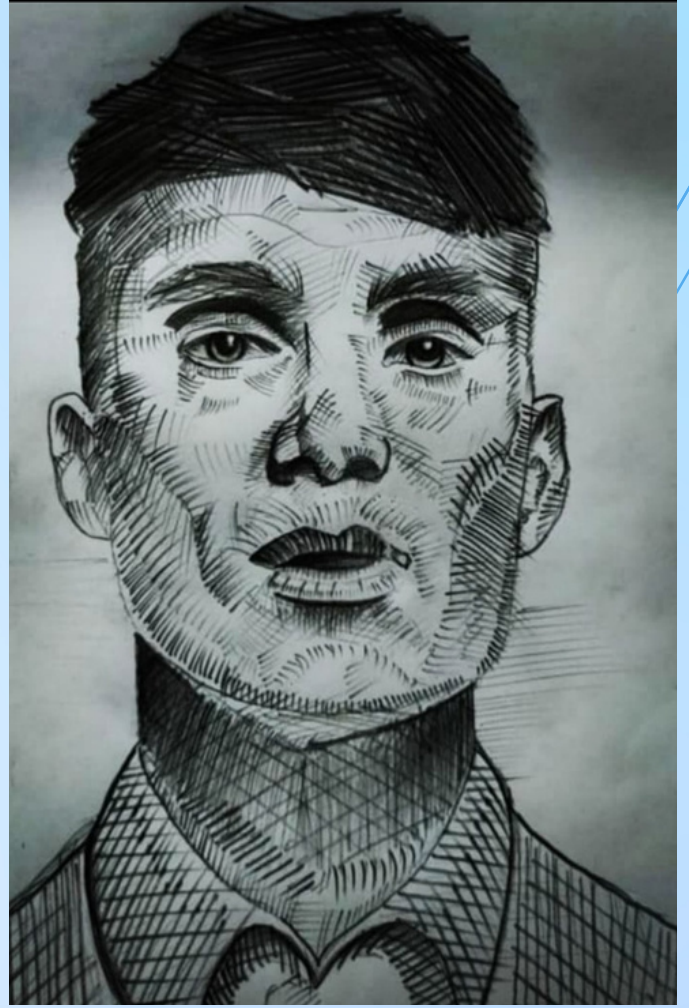

**-VEERESH HANJI (MECH 3A)**

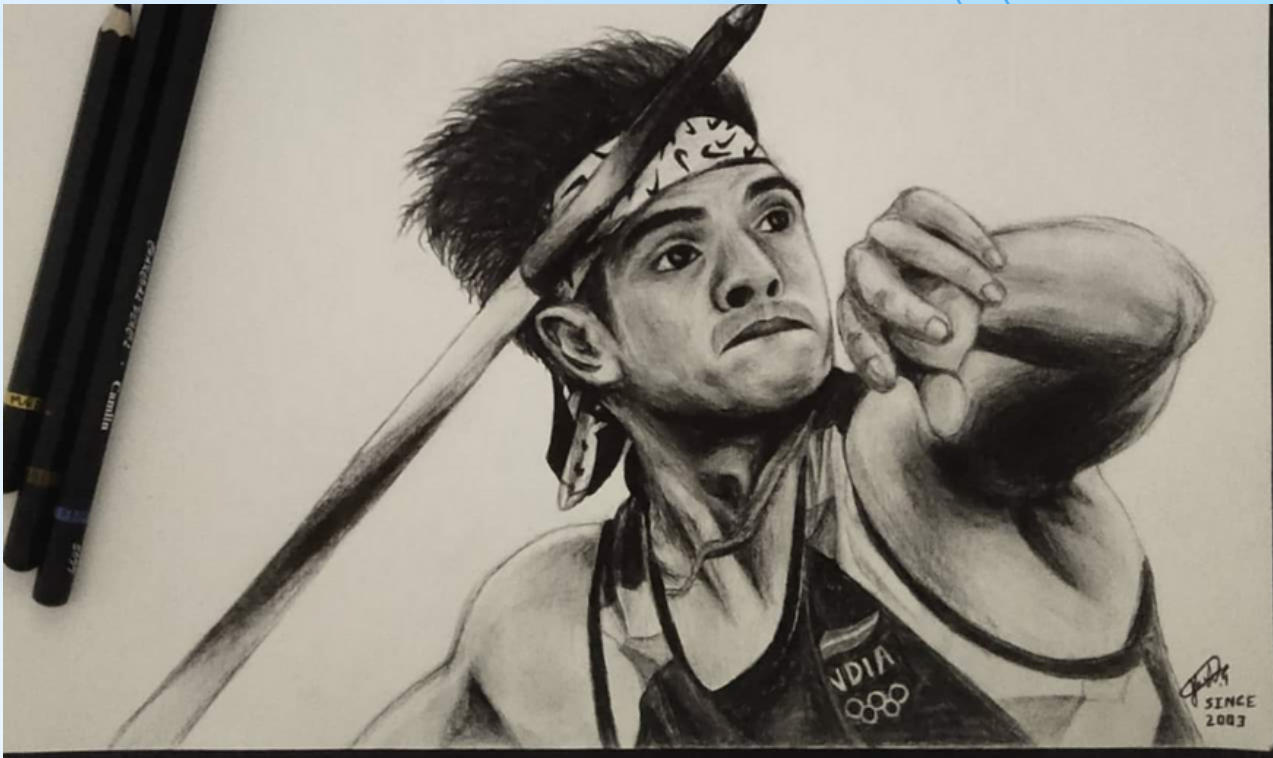

**-YASH  
GHARE  
(MECH 3A)**



**-SHRUTI SHINDE (MECH 5B)**



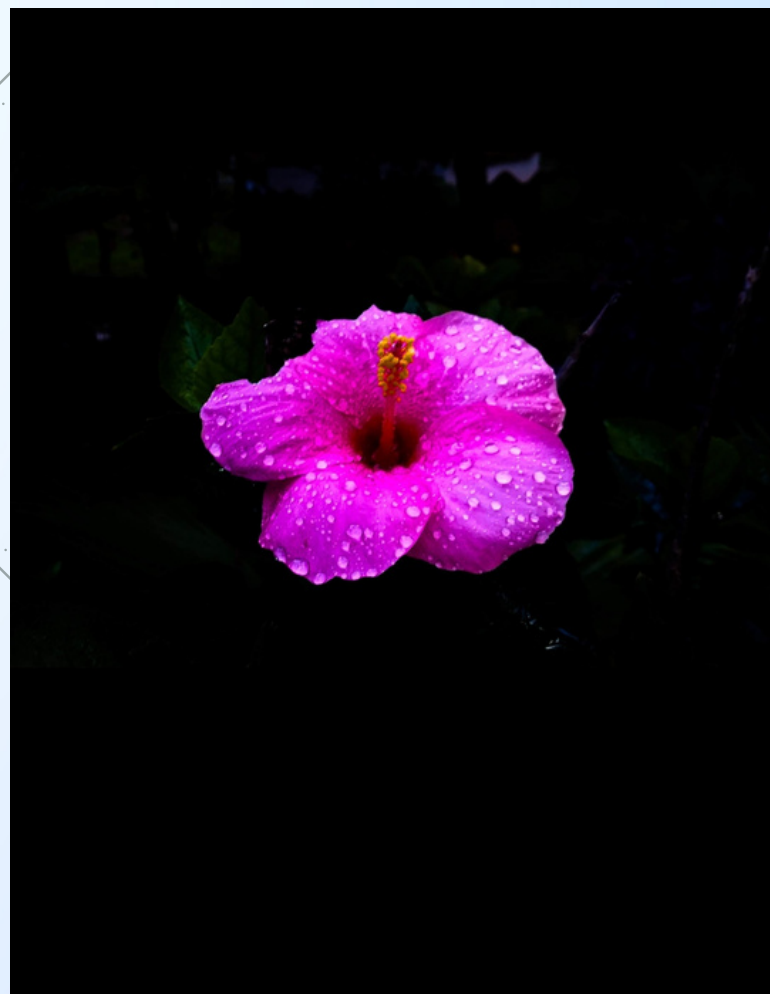

**-YASH CHAUDHARY (MECH 7B)**



# -PRADNYA BOKADE (MECH 5A)

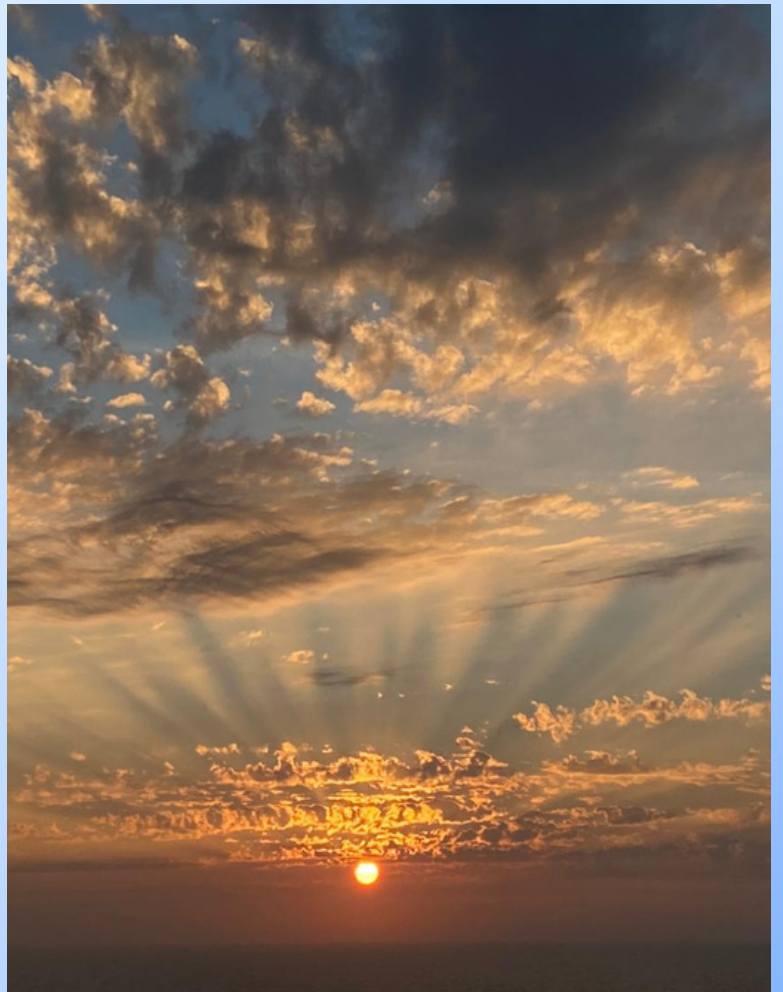

**-SIDDHI SURVE (MECH 5 B)**

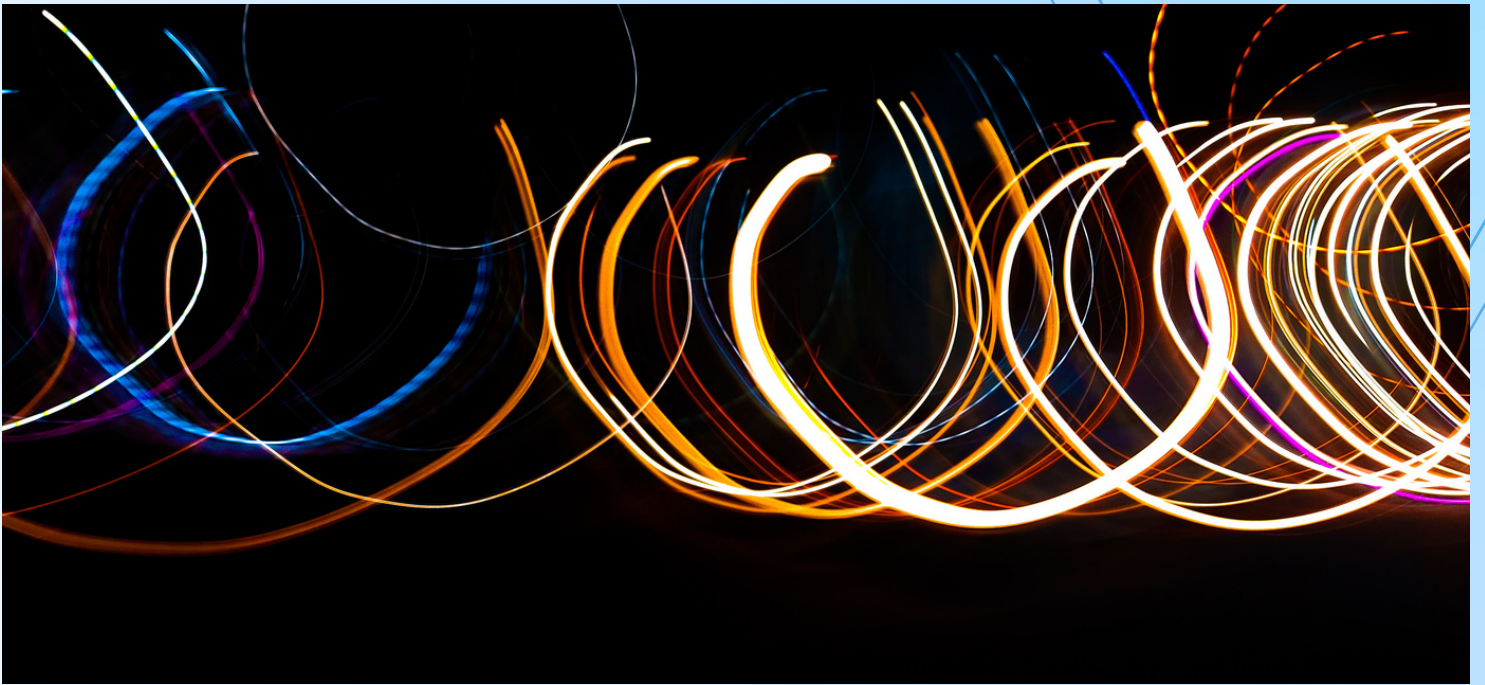

**-ATHUL KRISHNA.T.B(MECH 3A)**



**-MONISH BAFNA (MECH 5B)**

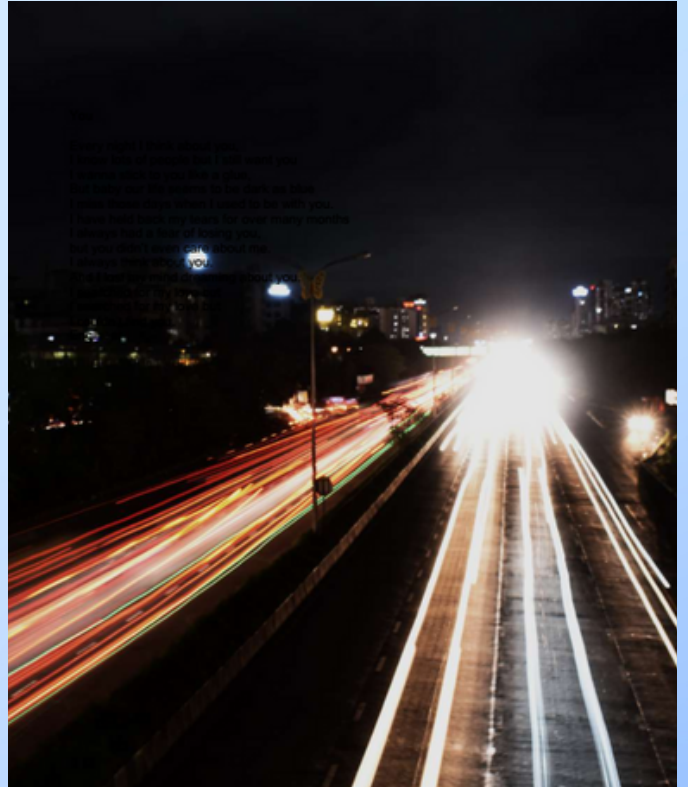

**-AMEY YEWALE (MECH 3B)**

# STUDENT'S ACHIEVEMENTS

<b>Sr. No</b>	<b>Name</b>	<b>Name of the events /competition/workshop etc</b>	<b>Organizing Institute/Body and its location</b>
1	J OM PRASAAD	TECHgium	L&T Technology Services
2	AAYUSH DINESH JADHAV	Faces 2021 chess event	Fr.C.R.I.T., Vashi
3	SHREYA DHOPEKAR	Muntazir Escape Room, FACES	Student Council, FCRIT Vashi
4	ABHISHEK SANTOSH MOHITE	Treasure Trove	FACES F.C.R.I.T
5	ABHISHEK JOSHI	Treasure Trove	Fr.C.R.I.T., Vashi
6	SAHIL GURAV	Treasure Trove	Fr.C.R.I.T., Vashi
7	KANNADKAR SIDDHARTH SACHIN	BREVETS DE RANDONNEUR MONDIAUX (BRMs)	AUDAX INDIA RANDONNEURS - AIR
8	ABHISHEK SANTOSH MOHITE	Treasure Trove	FACES Fr.C.R.I.T
9	CHINCHMALATPURE SUMEDH	Quizzeria Pharma and Healt	hSterling institute of Pharmacy
10	CHINCHMALATPURE SUMEDH	Organ donation and transplat	Public health office
11	YASH VAIDYA	Solidworks Associate exam	Dassault Systemes
12	CHINCHMALATPURE SUMEDH	Aakruti Collaborative Industr	Dassault Systems
13	CHINCHMALATPURE SUMEDH	Aakruti collaborative Buisness	Dassult Systems
14	HARSH CHAUDHARY	Associate - SolidWorks FULL	SOLIDWORKS by Dassault System
15	GAURAV SINGH	Invitational kickboxing fights	Navi Mumbai Mixed Martial Art

# STUDENT'S ACHIEVEMENTS

16	DIAS MALCOLM MICHAEL	Mechanical Design	Dassault Systemes
17	CHINCHMALATPURE SUMEDH	Mechanical Design	Dassault Systèmes
18	DIAS MALCOLM MICHAEL	Additive Manufacturing	Dassault Systems
19	CHINCHMALATPURE SUMEDH	Solidworks Certification exam	Dassault Systèmes
20	HARSH CHAUDHARY	Certified Solidworks Professional in Mechanical Design Exam (CSWP)	Solidworks by Dassault Systèmes
21	Aditya Bramhjeet Mishra	Ultra Marathon	FCRIT, TOTAL DEFENCE RUNS
22	RAJAM JAYESH SHRIKRISHNA	IDRL (Indian Drone Race League) event - Etamax 2022	Aero FCRIT and Student Council at Fr. Conceicao Rodrigues Institute of Technology, Vashi
23	ADITI SHINDE	MESH	MESA, FCRIT
24	BASKER ADITHYA	Swacchh Innovation Technology Challenge	NMMC
25	J OM PRASAAD	Technical Paper Presentation	Thakur College of Engineering and Technology, Kandivali
26	ATHARVA VANI	Torque	SAE
27	KANNADKAR SIDDHARTH SACHIN	BMW Cyclothon	BMW, Navnit Motors
28	KANNADKAR SIDDHARTH SACHIN	Dream F1	MESA, FCRIT
29	PRATHAM SALUNKE	ROCKET-X	MESA, FCRIT
30	MANAS KADU	ROCKET-X	MESA, FCRIT
31	PATIL SHREYASH SHAILESH	Technical paper presentation	MESA, FCRIT



# STUDENT'S ACHIEVEMENTS

32	VAITY PRATHAMESH RAJESH	Dream f1	MESA, FCRIT
33	PARKAR OMKAR RAJAN	Calibre	MESA, FCRIT
34	PAWAR PRATIKSHA VIJAY	Calibre 2K22	MESA, FCRIT
35	TAMHANKAR AMEY SANTOSH	CALIBRE PAPER PRESENTATION	MESA, FCRIT
36	D'SOUZA SANNIAL	Dream f1	MESA, FCRIT
37	VEIGAS JASON ULLAS	Caddict	MESA, FCRIT
38	ROSHAN THOMAS	Quido CALIBRE MESA	MESA, FCRIT
39	J OM PRASAAD	CALIBRE 2K22	MESA, FCRIT
40	KRISHNAN A BALASUBRAHMANIAN	National Level Technical Paper Presentation	MESA, FCRIT
41	BASKEY RUPAY LAXMAN	QUIZOPHILE	MESA, FCRIT
42	CHORGE KSHITIJ EKNATH	National level Technical Paper Presentation	MESA, FCRIT
43	SHETTY NATESH VIJAY	Calibre2k22	MESA, FCRIT
44	SOHAM RAVINDRA NEVGI	ROCKET X	MESA, FCRIT
45	LEON SAM BENJAMIN	Calibre2k22	MESA, FCRIT
46	YASH VAIDYA	Dream F1	MESA, FCRIT
47	VARGHESE NOEL	Dream F1	MESA, FCRIT

# STUDENT'S ACHIEVEMENTS

48	YASH CHAUDHARY	Calibre 2k22	MESA, FCRIIT
49	ADITI SHINDE	Calibre 2k22	MESA, FCRIIT
50	MISTARI VAIBHAV	Project Poster Presentation	MESA, FCRIIT
51	GUPTA SHREYANSH	CADDICT , Calibre 2k22	MESA, FCRIIT
52	PRATHAM UKIRDE	Calibre 2k22	MESA, FCRIIT
53	HARSH CHAUDHARY	Dream F1	MESA, FCRIIT
54	HARSH CHAUDHARY	Quido	MESA, FCRIIT
55	HARSH CHAUDHARY	Quizophile	MESA, FCRIIT
56	KALE YASH	National Level Project Poster competition NPPC	MESA, FCRIIT
57	BOHRA YASH VINOD	Etamax	Student council
58	SAURABH PATIL	ROCKET-X	MESA, FCRIIT
59	PARTH TRIVEDI	Calibre 2k22	MESA, FCRIIT
60	SIDDHESH PADATE	ROCKET X	MESA, FCRIIT
61	ALI ASHRAF GILANI	Quizophile	MESA, FCRIIT
62	VAZAPULLY MELISSA	Quido	MESA FCRIIT

# FACULTY ACHIEVEMENTS

Name of Faculty	Paper Title	Journal Name	Publisher
Badal Kudachi	Experimental and computational study of phase change material based shell and tube heat exchanger for energy storage	Materials Today: Proceedings	Elsevier Ltd.
Sanjay Rukhande	Investigation of Friction and Sliding Wear for Journal Bearing Using Taguchi Optimization	IEEE Xplore	IEEE
Aqleem Siddiqui	Damage Detection in beams using Vibration analysis and Artificial Neural Network	IEEE Xplore - ICNTE-2021	IEEE Xplore
Nilaj Deshmukh	Effect of position of radial air injection plane on control of thermo-acoustic instability using active closed-loop method	Journal of Vibration and Control	Sage Publication
Praseed Kumar	Effect of position of radial air injection plane on control of thermo-acoustic instability using active closed-loop method	Journal of Vibration and Control	SAGE
Afzal Ansari	Effect of position of radial air injection plane on control of thermo-acoustic instability using active closed-loop method	Journal of Vibration and Control	Sage Publication
Sanjay Rukhande	Tribological investigation of HVOF sprayed Ni-based coatings on SS 316L in water-cooled nuclear reactor	Materials Today: Proceedings	Elsevier
Sanjay Rukhande	Sliding Wear Investigation of Ni-Based Coating and SS 316L for Hydraulic Fracturing Tools in Water-Diesel Condition	Journal of Failure Analysis and Prevention	Springer Nature
Sanjay Rukhande	Ni-based coating protection of 316L stainless steel at dry, elevated temperature and wet sliding condition	Materials Today: Proceedings	Elsevier publication
Sanjay W Rukhande	Sliding Wear Investigation of Ni-Based Coating and SS 316L for Hydraulic Fracturing Tools in Water-Diesel Condition	Journal of Failure Analysis and Prevention	Springer Nature
Sanjay Rukhande	Ni-based coating protection of 316L stainless steel at dry, elevated temperature and wet sliding condition	Materials Today: Proceedings	Elsevier
Dr. S. M. Khot	Development of Low-Cost Optimal Magneto-rheological Damper for Automotive Application	Journal of Vibration Engineering & Technologies	Springer Nature Switzerland
Praseed Kumar	Mapping, Trajectory, Planning and Navigation for Hexapod Robots using ROS	Springer	Springer

# FACULTY ACHIEVEMENTS

Faculty Name	Paper Title	Full Name of Conference	Name of Organizing Institute with place
Mr. Praseed Kumar	Characterization of Magneto-Rheological Damper	4 th Biennial International Conference on Nascent Technologies in Engineering -ICNTE - 2021	Fr. C. Rodrigues Institute of Technology -Navi Mumbai, Maharashtra, India
Dr. Nilaj Deshmukh	Effects of Volume and Neck Length of Helmholtz Resonator on Thermo-acoustic Instability	4th Biennial International Conference on Nascent Technologies in Engineering (ICNTE-21)	Fr. C. Rodrigues Institute of Technology, Vashi
Mr. Badal Kudachi	Experimental and Numerical Investigation of Latent Heat Based Energy Storage System Using Nano Enhanced Phase Change Material	2nd International Congress on Advances in Mechanical and Systems Engineering (CAMSE-2021) Conference	Dr. B. R. Ambedkar National Institute of Technology Jalandhar
Mr. Badal Kudachi	Thermal Analysis of Earth Tube Heat Exchanger Using Experimental Setup and Simulation	2nd International Congress on Advances in Mechanical and Systems Engineering (CAMSE-2021)	Dr. B. R. Ambedkar NIT Jalandhar, Punjab, INDIA
Mr. Bipin Mashilkar	Experimental and Numerical Investigation of Latent Heat Based Energy Storage System Using Nano Enhanced Phase Change Material	2nd International Congress on Advances in Mechanical and Systems Engineering (CAMSE-2021)	Dr. B. R. Ambedkar National Institute of Technology, Jalandhar
Dr. Sanjay Rukhande	Ni-based coating protection of 316L stainless steel at dry, elevated temperature and wet sliding condition	International Conference on Advancements and Futuristic Trends in Mechanical and Materials Engineering	IIT, Ropar
Dr. Sanjay Rukhande	The surface properties enhancement using coating: A Review	International Conference on Advancements and Futuristic Trends in Mechanical and Materials Engineering	IIT, Ropar
Dr. Sanjay Rukhande	Tribological investigation of Nickel based coatings in water-cooled reactor	International Conference on Advancements and Futuristic Trends in Mechanical and Materials Engineering	IIT, Ropar
Mr. Deepak Devasagayam	Analysis of Thermal Battery Management Systems for Lithium-Ion Battery Cell	20th ISME CONFERENCE ON ADVANCES IN MECHANICAL ENGINEERING	Indian Institute of Technology, Ropar, Rupnagar, Punjab-140001, India
Mr. Praseed Kumar	RESIDUAL STRESS PREDICTIONS IN WELDED PLATES USING ARTIFICIAL NEURAL NETWORK AND EXPERIMENTAL VALIDATIONS	International Conference on Applied Mechanics, Machine Learning and Advanced Computations	NIT , Raipur
Mr. Badal Kudachi	Analysis of Thermal Battery Management Systems for Lithium-Ion Battery Cell	20th ISME(Indian Society of Mechanical Engineers) Conference on Mechanical Engineering	Indian Institute of Technology Ropar (IIT Ropar)
Mrs. Pallavi Khaire	Condition Monitoring of Rolling Element Bearing Having Defect at Outer Trace Using Machine Learning	76th Annual Meeting & Exhibition Walt Disney World Swan and Dolphin Resort   Orlando, Florida (USA) May 15-19, 2022	Society of Tribologists and Lubrication Engineers, an international organization
Mrs. Pallavi Khaire	CONDITION MONITORING OF BALL BEARING HAVING DEFECT AT INNER RACE USING VIBRATION ANALYSIS AND MACHINE LEARNING	Society of Advanced Materials and Process Engineering SAMPE Conference and Exhibition, North America's Premier Advanced Materials & Process Engineering Conference & Exhibition Seattle, USA	Society of Advanced Materials and Process Engineering (SAMPE)

# PLACEMENT DATA

SR. NO.	NAME	NAME OF THE COMPANY
1	Suryateja Chadalawada	Cognizant
2	Ankit Singh Chouhan	TCS
3	Chinmay Desai	Sciative
4	Samantha Dias	Cognizant
		JSW
5	Arpit Amol Khope	TCS
6	Wilfred Lewis	Cognizant
7	Shanto Saji Mathai	Cognizant
		Godrej & Boyce
8	Jebastin Durai Nadar	TCS
9	Akshata Patil	Cognizant
		Schneider Electric
10	Ruchita Mahadeo Patil	Cognizant
		JSW
11	Ruben Florano Pereira	TCS
12	Rohan Pulimoottil Mathew	Sciative
		Godrej & Boyce
13	Monali Patil	Burns MCD
14	Sarthak Bharade	Q Spider
		JSW
15	Vaishnavi Pradeep Dhake	Q Spider
		Godrej & Boyce
		SARMAN ENGINNERING
16	Rayan Robert Rego	Q Spider
17	Tejas Shirsat	Q Spider
		Surmount Energy (Maxval)

# LIST OF TOPPERS

SEMESTER	NAME	CGPI
SEM 4	JAGRAJ TEJINDERPAL SINGH	9.98
SEM 4	MAYUR PARAB	9.96
SEM 4	SHREYASH PARAB	9.94
SEM 6	SHREYANSH GUPTA	9.96
SEM 6	J OM PRASAD	9.79
SEM 6	PAWAN GOLE	9.77
SEM 8	RAHUL SHELAR	9.75
SEM 8	SHUBHAM DIXIT	9.70
SEM 8	AKSHATA PATIL	9.67
SEM 8	MONALI PATIL	9.67

# SYNERGY 2020-21

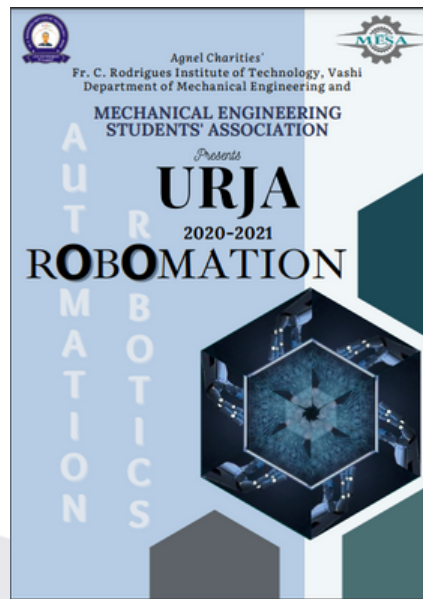

SYNERGY is organized with the aim of bridging the gap between the industry and the institute and facilitates an effective interaction between them. This event provides an opportunity for the students as well as the faculty members to know more about the emerging technologies and methodologies adopted by the industry. Also, the industry in turn, gets to know the institute closely, thereby providing an opportunity to identify the value addition required to create high class professionals from the institute. Synergy 2021 was the latest edition of our vibrant and vigorous industry-academia interaction.

It was held on 18 th September 2021 at the premises of our very own college Fr. C. Rodrigues Institute of Technology, Vashi. We were fortunate to have guest speakers from Tenneco Clean Air India Pvt. Ltd (Chakan ,Pune) to interact with students. Mr. Santosh D. Satre (Designation: Senior Engineer CFD) and Mr. Omkar Gaikwad (Designation: Senior Engineer CAE) were the keynote speakers who graced us with their presence and shared their valuable knowledge and experience with students. The speaker dealt with technical aspects of and opportunities in their field. It was followed by an open interaction where there was wholehearted involvement from the students.

# PRESIDENT'S NOTE 2020-21



We began our journey as a family, learning about MESA from our senior members. They aided us in acquiring new skills, learning new software, and most importantly, in trusting each other while working as a team. Working under the senior council's direction, we successfully completed Synergy 2020 and Mesh 2021. But, with their guidance and understanding, we marched forward with confidence and determination for the next year. New members joined our team, became a part of the Mesa family, and together we planned and conducted Synergy 2021 and Mesh 2022, which helped the team members improve their coordination and understanding, bridged the gap between our ideas and perspectives, refined our skills, and prepared us for our technical fest, Calibre 2k22. We started planning with the help of our lecturers, while also coordinating with the HOD. We attempted to come up with new ideas for events that would take place throughout the fest while keeping in mind the perspectives and learning experiences of previous events. On the other hand, we kept the digital functioning of the fest in mind and worked hard with our promotion activities.

The team pushed their limits to think creatively by becoming socially engaged on various social media platforms and addressing other colleges across the country. Simultaneously, sponsorship was a time-consuming activity because meetings used to be scheduled at any random time, maybe during lectures or late in the evening, but thanks to the team's sincere efforts, we were able to collect a substantial amount that helped us go through with all our plans. Because of our hard work and dedication, the fest was extended to a three-day grandeur. With all activities running concurrently, everything went as planned, and when the event date arrived, we were all extremely excited. The first day of Calibre 2k22 began, and all of the scheduled events received overwhelming support and positive feedback. It was a genuinely happy moment for all of us at the end of the third day; everyone was overjoyed; it felt like a dream. But MESA's journey was also coming to an end. Being a part of MESA for two years was one of the best experiences we could have had. But at the end, we must keep moving forward and pass on our heritage to the junior members, wishing them the best of luck on their journey. Finally, I'd like to express my gratitude to all of my colleagues for their constant support, as well as the faculty coordinators for their belief in me and my team and all of MESA's well-wishers.

- Adithya Basker  
President Mesa 2021-2022



# PRESIDENT'S NOTE 2021-22



. I still remember each and every moment from the first day to the present day. It seems like yesterday was the day when I had my first day at this place. All the people were unaware and there was fear and hesitation in their minds. Time passed slowly, a special and different relationship was attached to this place. If there is any place after my family where I have to spend most of the time, then this is the place this is my second home. Being our seniors they aided us in acquiring leadership skills, learning new software, problem-solving and managing skills, and most importantly, trusting each other while working as a team. Working under the senior council's direction, we successfully completed Synergy 2020 and Mesh 2021. With their guidance and understanding, we marched forward with confidence and determination for the upcoming challenges. We started planning with the help of our faculty members, while also coordinating with the HOD. We attempted to come up with new ideas for events that would take place throughout the fest while keeping in mind the perspectives and learning experiences of previous events. On the other hand, we kept the digital functioning of the fest in mind and worked hard with our promotion activities. The team pushed their limits to think creatively by becoming socially engaged on various social media platforms and addressing other colleges across the country.

Simultaneously, sponsorship was a time-consuming activity because meetings used to be scheduled at any random time, maybe during lectures or late in the evening, but thanks to the team's sincere efforts, we were able to collect a substantial amount that helped us go through with all our plans. Because of our hard work and dedication, the fest was extended to a three-day grandeur. With all activities running concurrently, everything went as planned, and when the event date arrived, we were all extremely excited. The first day of Calibre 2k22 began, and all of the scheduled events received overwhelming support and positive feedback. It was a genuinely happy moment for all of us at the end of the event leaving everyone overjoyed. Being a part of MESA for a complete year was one of the best experiences we could have had. New members joined our team, became a part of the Mesa family, and together we planned and conducted Synergy 2022, which helped the team members improve their coordination and understanding, bridged the gap between our ideas and perspectives, and refined our skills. After so much hard work, now is time to say goodbye but at the end, we must keep moving forward taking responsibility and passing on our heritage to the junior members, wishing them the best of luck on their journey. Finally, I'd like to express my gratitude to all of my colleagues and my senior members for their constant support, as well as the faculty coordinators for their belief in me and my team and all of MESA's well-wishers.

- Leon Benjamin  
President Mesa 2022-2023

# ISHRAE COLLEGIATE CHAPTER

The Indian Society of Heating Refrigeration and Air Conditioning Engineers (ISHRAE) was founded to promote the HVAC industry in India. The student chapter aims to provide the student members with industry exposure and get them more involved in HVAC. The ISHRAE student chapter of FCRIT was started with the goal of getting new opportunities for students in the field of HVAC specifically and providing a stable career in the same. The FCRIT chapter was initiated on 22nd September 2007. Mr Nilesh Varkute, Mr Badal Kudachi and Ms Neha Pandit are the faculty advisors of the FCRIT chapter. ISHRAE organizes various events like Exhibitions, Quizzes, Technical Paper Presentations, Industrial visits, Job Junctions, etc.

The installation of the Students Chapter, FCRIT, 2021 – 2022, was conducted virtually on Zoom Meeting. This event was attended by the appointed council of the FCRIT Chapter (President, Secretary, Treasurer and Committee Members) along with the Faculty Advisor and other ISHRAE Student Members. The chief members of the Mumbai Chapter Mr Mihir Sanghvi, Sanjay Verma, Mr Amod Dikshit, Mr Sanjay Jadhav and Mr Vivek Marde gave some encouraging words. This was followed by the installation of the President, Secretary and Treasurer of each Student Chapter by Mr Sanjay Verma. After that, the present Student President Mr Shubham Dixit shared his experience in ISHRAE and gave a brief about the future activities to be held at FCRIT under his leadership. Mr Baniz Antony, the Secretary, gave a vote of thanks to all the chief guests.

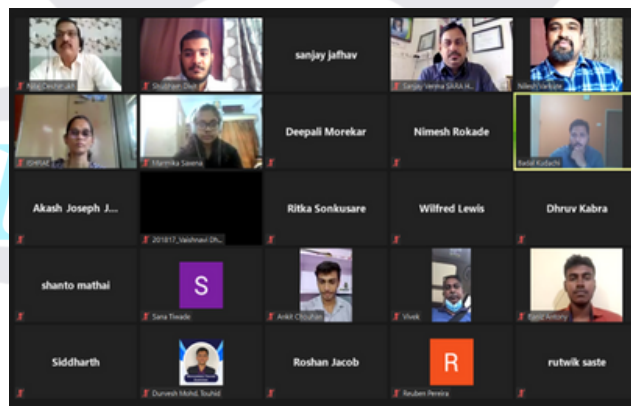

Industrial Visits were organized to bridge the gap between the students and industries ISHRAE conducted two Industrial Visits to Zeco Aircon Limited factory, Aatgaon, Thane and Kruger Ventilation Industries (India) Pvt. Ltd, Shahapur, Thane. At Zeco Aircon Limited students learned about the world-class manufacturer of Air Management systems, delivering reliable and superior quality products. Their product range includes Air Handling Unit (AHU) – Double Skin/ Single Skin, Fan Coil Unit (FCU), Air Washers (Evaporative Cooling Unit) – Single / Double Stage, Air Scrubber-Wet type/ Dry-type (ESP Technology), Rectangular Factory Fabricated Duct (GI /AL/SS), Pre-Insulated Ducting (PIR Panel Duct).



At Kruger Ventilation Industries Pvt. Ltd., the students learned about different applications of FAN, the process of FAN selection according to CFM, the selection criteria of the FAN as per static load, and different shapes and types of blades used as per load requirement. The students also had a hands-on experience with different Axial Fans, Centrifugal Fans, Domestic Fans, In-Line Fans, Jet Fans, Mixed Flow Fans, Roof Exhaust Fans and Tunnel Fans. KrugerVent is Kruger's one-stop product selection software. This web-based software will guide you in selecting the product, budgeting and also submittals from the beginning to the end of your project. It is able to adapt to the different situations that may appear. The students experienced a very mind-boggling visit where they got to know so much about how a ventilation system is designed and manufactured from the start to the end which surely piqued their interest in the HVAC field and other fields which go hand in hand with HVAC.



ISHRAE's K-12 committee works to advance the awareness, understanding, and appreciation of science, technology, engineering, and math (STEM) in the K-12 student population. ISHRAE FCRI Chapter conducted overall four K12 Activities, such as Yoga Session, an Educational session, Sports Session and Motivational Session.

Yoga Session was organized for Bal Bhavan Students to increase awareness of physical and mental health in the form of Yoga asanas. They were made to do some basic exercises and Yoga asanas under the guidance of Yoga teacher Mr Dhruv Kabra. Different Yoga Asanas were performed during the session such as Omkar, Kapalbhati, Surya Namaskar, Vrikshasana, Demo of Nauli and Shirsasana. Children of all age groups were made aware of certain benefits of Yoga such as it improves posture and flexibility, helps to increase metabolism and mental health, and increases blood flow and self-esteem oneself.

Educational Session was organized for Bal Bhavan Students to increase awareness regarding climatic changes and their effects on the environment. So topics like global warming, plastic waste and pollution and its effects and possible solutions were demonstrated in video format by Mr Baniz Antony. Mr Nilesh Varkute sir covered topics like possible sources of energy such as solar, wind, nuclear and tidal energy. Students learnt the ways to dispose of plastic waste and reduce pollution in order to prevent climatic changes which are harmful to the environment.



Sports Session was organized for Bal Bhavan Students to increase awareness towards physical and mental health by playing a lot of fun sports. Many different sports were conducted in order to increase the fellowship between them and to make them aware of the importance of outdoor games. Students were able to understand the significance of sports in their day to day life. Concepts such as physical as well mental well-being, physical fitness and the need for awareness for physical activity were introduced to the students. Motivational Session was organized for Zilla Parishad Prathamik Shala, Ambele, Murbad, Thane Students to increase awareness on focusing on career as many students just got into offline mode of education and couldn't focus on their academics. So topics like Focus was taken up by Mr. Shubham Dixit. Further the students were told about the need to be confident, hardworking, to build a good attitude and to showcase their talent. To make them aware about different career opportunities which they can choose in their future. Students learnt the ways to be confident, hardworking, to build in good attitude and to showcase their talent.

To engage students in a problem solving activity to sharpen their critical thinking ability ISHRAE FCRI Chapter organized an Online Treasure Hunt for the participants across India. To install a critical thinking mindset in all of the participants attending the online treasure hunt. In this national level competition a total of 13 teams comprising of 31 students from all over India participated in the online treasure hunt. IMC Student Chair Mr. Vivek Marde were the chief guest of the online event. Students participated in a fun and interactive session and took it as an opportunity to showcase their talent and problem solving abilities. Critical thinking mindset was developed among the students in order to solve problems and be rational in their way of thinking.

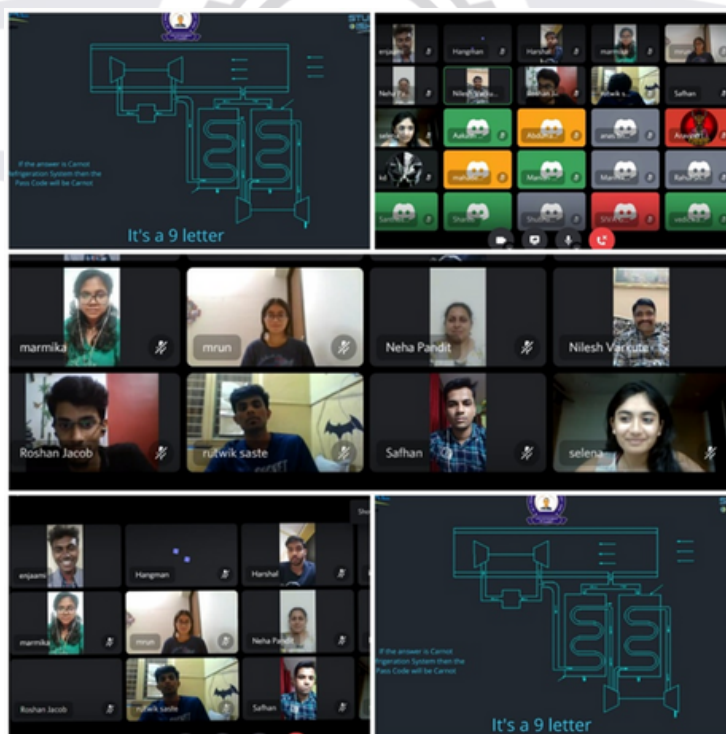

# SAE COLLEGIATE CHAPTER

SAEINDIA is an affiliate society of SAE International registered in India as an Indian non-profit engineering and scientific society dedicated to the advancement of mobility industry in India. The founding principle of SAE International is to unite scientific and technical staff to perform free academic discussions, dedicate themselves to the cause of prospering the science and technology for automotive vehicles and to make contributions to speed up the modernization of the automotive industry. The Club actively organizes various events such as TORQUE- Intercollege event of Nitro Racing and IGNITION- Seminar by speakers from the automobile sector. Prof. Girish Dalvi and Dr. Aqleem Siddiqui are the faculty advisors for SAEINDIA COLLEGIATE CHAPTER. The Mechanical Department has an SAE Collegiate Club, having more than 50 members.

## EVENT-TORQUE

SAE India FCRIT is a collegiate club that focuses on fuelling students with automotive knowledge. It conducts various technical events throughout the year, torque being its main highlight. It was conducted on the first day of etamax i.e 10th March 2022. Torque is a nitro radio-controlled car racing competition where exuberant & zestful participants race their RCs on tracks full of obstacles. This year the inertia of rest from the pandemic of all participants was overcome by highly driven “Torque 2022”. The Torque 22 had conducted various track events including endurance races, stunt racing, and drag racing. The indefatigable work of supporting staff, council members, and volunteers made the event successful. Participants included students from overall Mumbai involving students of FCRIT and other colleges. It captivated a huge section of the audience including the entire staff and students. The participating teams gave the audience a splendid, brief, and elaborative show of their respective RC cars along with some fine driving lessons. They were also kind to share tips about maintenance and car building with the enthusiasts present. The winning team was awarded a cash prize of INR 5000 by the guest of honor which included Fr Sebi, principal sir Dr. SM khot head of department Dr. Nilaj Deshmukh with all other faculty members of the mechanical department.



## “ENGINEERING THROUGH MY VIEW”- WEBINAR

SAE INDIA FCRIT conducts various webinars and seminars to provide digital solutions to the technical problem among them is an annual expert lecture series called ‘Ignition X’ where industrial experts or alumni ignite innovative minds to solve any technical problem with their words of wisdom. The event was conducted on 2nd Feb 2022 giving insights into the engineering journey of the speaker Mr. Ruturaj Chavan alumni, ex BAJA captain, and a vibrant team player who was adept in his field of knowledge. The session began with the speaker’s introduction to his experience of engineering and how he perceived and pursued it. Mr. Chavan is the former of ‘Team Kaiser Racing’ and had a venturesome approach during his engineering days. The drive down to his memory lane of experience motivated the student toward an innovative and technical world. Speaker emphasized interpersonal skills, an open approach to applications, and, project-based learning. He shared his struggle in the initial days of forming team Kaiser and the car. He mentioned the support given by the faculty without whom just like the racing car he wouldn’t withstand his journey. He also spoke about the on-field journey of the car and how they bagged the prize. The open, frank, and robust nature of the speaker engaged the students. He shared how participating in multiple clubs and cells helped him develop his personality. Mr. Chavan then made us aware of the placement training sessions and why he chose placement over higher studies. He explained to us the advantages and limitations of placement and higher studies. The session was then concluded by the Q&A section and a vote of thanks by the SAE council. The session ‘engineering through my view’ changed our perspectives on engineering.

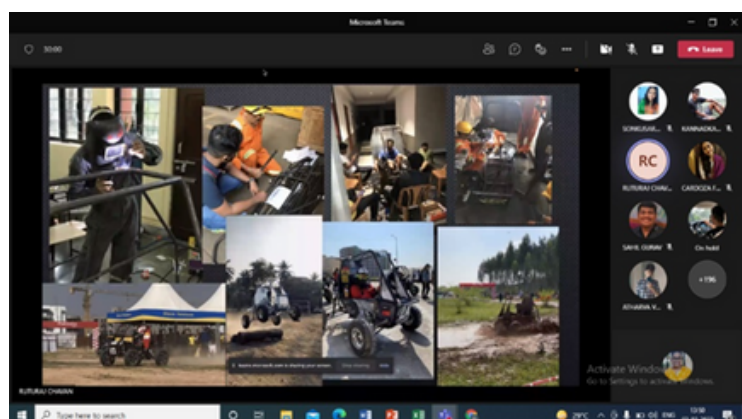
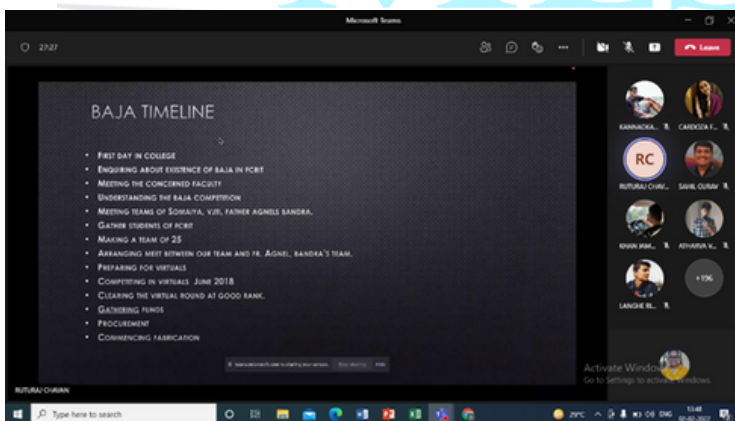

# BAJA INDIA

Our SAEINDIA collegiate team “Team Kaiser Racing” consists of 30 automobile enthusiasts who take part in events that include the design and fabrication of an ATV as well as the actual event which includes an endurance race. The team is led by Captain Siddharth Kannadkar and Vice-captain Harsh Chaudhary and guided by faculty advisors Dr. Dhananjay Panchgade and Mr. Sandeep Arote. The competition is a measure of how well a vehicle is designed, modeled, and constructed in all respects. The overall participation and innovation by students are proof that mechanically and aerodynamically sound buggies are just the beginning of FCRIT’s contribution to the automobile sector.

The team made a stunning debut two years ago, the team made sure the alterations concerning design improvement were implemented and the car stood tall and roared well before the event. This marked the beginning of, what would prove to be, a very successful journey.

The journey from the inauguration to the event is never a cakewalk, the team faced challenges befalling it with sleepless nights and tiring days. The path was narrow and curvy but the team drifted through each turn with a firm mindset.

In 2018-19, TKR was Ranked 129th of 295 teams, ranked 14th in the final endurance test, ranked 1st among new teams in the final race, and ranked 13th in the Design Evaluation report. In 2019-20, TKR was one of only 32 teams to finish the endurance test, ranked 43rd all over India in virtual rounds and 15th in the Design Evaluation report. In the 2020-21 edition of BAJA, TKR ranked 55th all over India in the Sales event of the virtual rounds. Unfortunately, due to the COVID-19 pandemic, it was not possible to conduct BAJA. This year the team is ready to take up the challenges and make its debut in 2023 BAJA events with even more enthusiasm.

Innovations keep the team pushing forward, defining new limits, and conquering new goals. This year for the first time TKR is designing and fabricating a 4WD vehicle.

The comeback of the team from the pandemic won't be easy, but with the motivation and hunger that fills the team's mindset, the team definitely will be a shining star throughout the season!



# AERO FCRIT

A team of 7 members aspiring to fly high, set a spark for the foundation of Aero Club in 2019. The team registered for their first event SAE Aero Design Challenge in August 2019 and started with the journey of Aero Design i.e., the designing and fabrication of a highly stable heavy lifting RC aircraft falling under given constraints.

All the efforts put in by every member of the team paid off, as they secured an impressive 5th place in the technical presentation round and 16th for the report submitted in the year 2020 and secured third place in the technical report submission round in the year 2021.

For this year 2022-23 we the members of AeroFCRIT are fully prepared for the SAE Aero design Challenge, as we have designed and fabricated the fixed wing UAV throughout the course of this year and will be competing for the same.

In this year we are leading the foundation of the drone department in our AeroFCRIT and from the year 2023-24, AeroFCRIT is going to participate in two departments i.e., Fixed wing (planes) department and Multirotor (drone) department.

We also collaborated with DRONACHARYA i.e., a group of industry experts that provide drone solutions across multiple domains, and organised a webinar for giving information about the use of multi-rotors in today's industry.

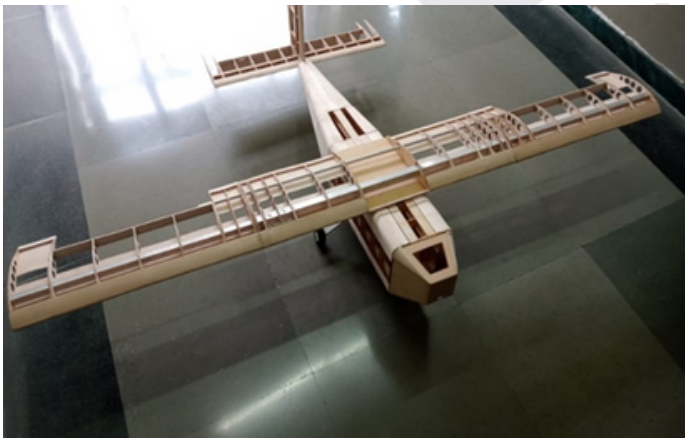

In March, 2022 our club organised a national level drone racing event known as IDRL (Indian Drone Racing League) in our college. This event was organised in our college fest, ETAMAX and was the first event of IDRL to be held at Navi Mumbai. A total of around 25 pilots from all over India participated in the event. This event was a grand success of ETAMAX and got our club the recognition it deserved.





# COUNCIL OF VIBRATION SPECIALISTS INDIA



CVS (council of vibration), a non-profit organization (first of its kind in the country exclusively on Vibration) has been formed by a few expert professionals dedicated to Vibration Science and Engineering, both from academia and industry in order to scale up the reach of this interdisciplinary specialization. CVS has set off with a mission to deliver valuable guidance to a wide range of audiences including students, industry engineers and technicians. It is crafted with a unique approach to training the intended audience by adapting to the practical understanding of the subjects. This incorporates demonstration of practical training, hands-on experience in vibration instrumentation, simulation studies, and suiting the latest technological upgrades.

Council Of Vibration Specialists Students Chapter is formed under the Mechanical Department Fr. C. Rodrigues Institute of Technology. The club has been created to undertake various practical activities around the world in the field of vibration. The inaugural ceremony of the Council Of Vibration Specialists Students Chapter took place on 11th April 2022 in the esteemed presence of Dr Harvinder Singh Ghabhir, president of CVS, Dr Tarapada Pyne, Dr Srinivas V., Dr Arun Jalan, Dr Chinmaya Kar, Dr Vasantand an FCRIT Alumnus. It was also graced by our principal Dr S. M . Khot and Faculty from the Mechanical department. Dr Harvinder Singh Ghabhir was the Chief Guest for the occasion. He spoke on a varied range of topics like Technology, History, Management and leadership. He narrated his journey into and after Reliance Industries and oil & gas refinery, Jamnagar his awe-inspiring professional experiences. His speech left the students thinking and inspired. Speaking on occasion Dr Tarapada Pyne said that, the purpose of this organisation is to provide its member's opportunities to gain broader insight into the engineering profession by sponsoring meetings that will bring practising engineers to the campus, arranging field trips and workshops to research and engineering establishments, sponsoring student projects of engineering interest, and participating in local CVS Section activities. Later, principal Dr S. M . Khot encouraged students with his words of advice and appreciation. The function ended with a presentation of mementoes to the chief guest and a vote of thanks by Mr Nageshwar Avhad, the president CVS Club Council.

# FACULTY PROFILE

<p><b>Dr. S. M. Khot (Principal)</b></p>	<p><b>Ph.D. (IIT Bombay)</b> – Aerospace Engineering  <b>M. E. (Shivaji University)</b> - Mechanical Design Engineering          Professor (Exp - 33 years)          Area of Research - Mechanical Vibration Dynamics and Control, Active Vibration Control, Smart Structures</p>
<p><b>Dr. Nilaj Deshmukh HOD and Dean (Faculty)</b></p>	<p><b>Ph.D. (IIT Bombay)</b> – Aerospace Engineering  <b>M. Tech. (VJTI, Mumbai)</b> - Automobile Engineering          Associate Professor (Exp.          - Industrial 2 years, Teaching - 22 years)          Area of Research - Virtual instrumentation, Combustion, Combustion Instabilities, Measurement Techniques, Noise Analysis, Aerodynamics</p>
<p><b>Prof. T. Mathewlal</b></p>	<p><b>M. S. (BITS, Pilani)</b>  <b>B. Tech. (Mechanical)</b> - Systems Associate Professor          (Exp. -33 years)          Area of Research - Engineering Mechanics and Thermal Engineering</p>
<p><b>Dr. Aqleem Siddiqui</b></p>	<p><b>Ph.D. (Mumbai University)</b>  <b>M. E. (Mumbai University)</b> - Machine Design          Associate Professor (Exp.- 23 years)          Area of Research - Active Vibration Control, Automobile Engineering, Design</p>
<p><b>Dr. Dhananjay Panchagade</b></p>	<p><b>Ph.D. (Mumbai University)</b>  <b>M. E. (Mumbai University)</b> - Mechanical Associate Professor (Exp. – Industrial – 6 years, Teaching – 9 years)          Area of Research - Machine Design</p>

<p><b>Prof. N. G. Kshirsagar</b></p>	<p><b>M. Tech. (VJTI Mumbai) - Machine Design</b> Assistant Professor (Exp.- 24 years) Area of Research – Design, MEMS, Synthesis of Mechanism</p>
<p><b>Prof. Prasad Bari</b></p>	<p><b>Ph.D. Pursuing (VJTI, Mumbai)</b> <b>M. Tech. (VJTI, Mumbai) - Production Engineering</b> Assistant Professor (Exp. – Industrial - 5 years, Teaching - 15 years) Area of Research - Micromachining</p>
<p><b>Dr. Sanjay Rukhande</b></p>	<p><b>Ph.D. (VJTI, Mumbai)</b> <b>M.E. (SPCE Mumbai) - Machine Design</b> Assistant Professor (Exp. – 21 years) Area of Research - Design, Analysis, Finite Element Method, Surface and Coating</p>
<p><b>Prof. Shamim Pathan</b></p>	<p><b>Ph.D. Pursuing (IIT, Bombay)</b> <b>M.E. (Mumbai University) - Machine Design</b> Assistant Professor (Exp. – 14.5 years) Area of Research - Vibration Measurement, Condition Monitoring and Fault Diagnosis</p>
<p><b>Prof. Bipin Mashilkar</b></p>	<p><b>M. E. (Mumbai University) - CAD/CAM and Robotics</b> Assistant Professor (Exp. – 15.5 years) Area of Research – CFD</p>
<p><b>Prof. Pallavi Khaire</b></p>	<p><b>Ph.D. Pursuing (VJTI, Mumbai)</b> <b>M. E. (Mumbai University) - Machine Design</b> Assistant Professor (Exp. – 13.5 years) Area of Research - Mechanical Vibration, Machine Design and Condition Monitoring</p>

<p><b>Prof. Praseed Kumar</b></p>	<p><b>M. E. (Mumbai University) - Machine Design</b> Assistant Professor (Exp. – Industrial - 8 years, Teaching - 14 years) Area of Research - Active Vibration and Control, Control Systems, Smart Materials and Measurement</p>
<p><b>Prof. Kamlesh Sasane</b></p>	<p><b>M. E. (Mumbai University) - Machine Design</b> Assistant Professor (Exp. – 14.5 years) Area of Research - Design Analysis, Mechanical Vibrations, Automobile and Mechanical Materials</p>
<p><b>Prof. Deepak Devasagayam</b></p>	<p><b>M.E.(Old Dominion University, US)- Mechanical Engineering</b> Assistant Professor (Exp. – Industrial - 5 years, Teaching – 11 years) Area of Research - Manufacturing, Production, Solar</p>
<p><b>Prof. Nilesh Varkute</b></p>	<p><b>M. E.(Mumbai University) - Thermal Engineering</b> Assistant Professor (Exp. - 13 years) Area of Research - Computational Fluid Dynamics, Heat Transfer, Renewable Energy and Energy Management</p>
<p><b>Prof. Girish Dalvi</b></p>	<p><b>M. S. (Politecnico Di Milano, Italy) - Mechanical Systems Design</b> Assistant Professor (Exp. - 12 years) Area of Research - Vibration Measurement and Analysis, Virtual Instrumentation and Mechatronics</p>

<p><b>Prof. Suvarna Rode</b></p>	<p><b>M.E. (Mumbai University) - Machine Design</b> Assistant Professor (Exp. – Industrial - 3.5 years, Teaching - 13.5 years) Area of Research - CAD/CAM, Smart Material and Structures</p>
<p><b>Prof. Badal Kudachi</b></p>	<p><b>M. Tech.(VTU, RC, Mysore) - Thermal Power Engineering</b> Assistant Professor (Exp. – Industrial – 0.5 years, Teaching – 8 years) Area of Research – Renewable, Thermal Barrier Coating, CFD and Energy Storage</p>
<p><b>Prof. Mohammad Afzal Alam Ansari</b></p>	<p><b>M. Tech. (IIT Bombay) - Aerospace Propulsion</b> Assistant Professor (Exp. – Industrial - 6 months, Teaching – 8 years) Area of Research – Propulsion, CFD, FEA, Combustion, Thermoacoustic</p>
<p><b>Prof. Shoumik P. Kulkarni</b></p>	<p><b>M. Tech. (WCE) – Mechanical Design Engineering</b> Assistant Professor (Exp. – Teaching – 5 years) Area of Research – Mechanical Vibrations, Vibro- Acoustics</p>
<p><b>Prof. Amar Murumkar</b></p>	<p><b>M. E. (Mumbai University) - Manufacturing Systems Engineering</b> Assistant Professor (Exp. – Industrial - 8 Years, Teaching – 7 Years) Area of Research – Quality, TQM, Six Sigma and Cost of Quality</p>

<p><b>Prof. Sunny Sarraf</b></p>	<p><b>M. Tech. (VNIT)- Mechanical Engineering / CAD/CAM</b>  Assistant Professor (Exp. – Industrial - 1 Years, Teaching – 6 years)  Area of Research –FEA, CAD CAM, 3D Printing and Bio-modelling</p>
<p><b>Prof. Shoaib Shaik</b></p>	<p><b>M. E. (Mumbai University) - Machine Design</b>  (Exp. – Teaching – 10 years)  Area of Research –Machine Design and Operation Research</p>
<p><b>Prof. Neha Pandit</b></p>	<p><b>M. E. – Heat and Power</b>  (Exp. – Teaching – 8 years)  Area of Research – Heat Power Engineering, Thermal Engineering, Cryogenics</p>
<p><b>Prof. Varad Deshpande</b></p>	<p><b>M. E. – Design</b>  (Exp. – Teaching – 4.5 years)  Area of Research – Machine Design</p>

